

TK-7108

SERVICE MANUAL / 维修手册

REVISED / 修订版

KENWOOD

© 2003-11 PRINTED IN JAPAN
B51-8592-10 (N) 621

This service manual applies to products with 50800001 or subsequent serial numbers.

In terms of the products with the serial numbers earlier than 50800001, refer to the TK-7108 service manual as per part No. B51-8592-00 or B51-8636-00.

本维修手册适用于50800001开始的序列号产品。
有关比50800001 早的序列号产品, 请参考编号为 B51-8592-00和B51-8636-00的TK-7108维修手册。

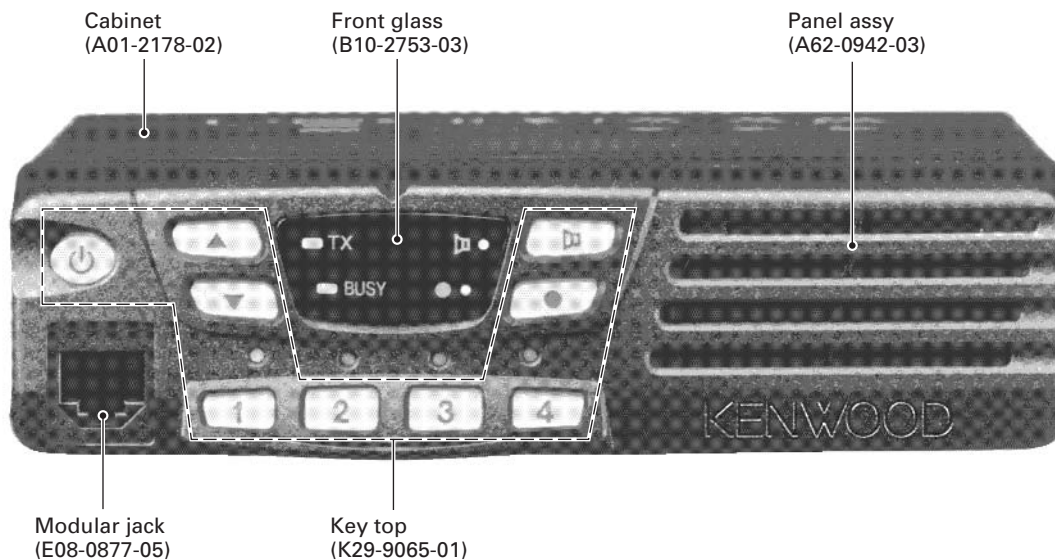

CONTENTS

GENERAL	2	PACKING	43
SYSTEM SET-UP	5	ADJUSTMENT	45
OPERATING FEATURES	6	TERMINAL FUNCTION	52
REALIGNMENT	13	PC BOARD	
INSTALLATION	19	DISPLAY UNIT (X54-3460-20)	54
DISASSEMBLY FOR REPAIR	23	TX-RX UNIT (X57-6913-01)	56
CIRCUIT DESCRIPTION	24	SCHEMATIC DIAGRAM	60
SEMICONDUCTOR DATA	32	BLOCK DIAGRAM	64
COMPONENTS DESCRIPTION	34	LEVEL DIAGRAM	66
PARTS LIST	36	SPECIFICATION	68
EXPLODED VIEW	42		

目 录

概 述	2	包 装	43
系统体系	5	调 整	46
操作特性	6	端子功能	53
模式组合	13	PC板	
安 装	19	DISPLAY UNIT (X54-3460-20)	54
维修时拆卸部件	23	TX-RX UNIT (X57-6913-01)	56
电路说明	24	原 理 图	60
半导体数据	33	方 块 图	64
元件说明	35	电 平 图	66
零 件 表	36	规 格	69
部件分解图	42		

Service Manual List

Title	Parts number	Remarks	Destination	TX-RX unit number	Display unit number
TK-7108	B51-8592-00		C, C2	X57-6293-XX	X54-3340-20
TK-7108	B51-8636-00	PDF only	M	X57-6293-01	X54-3340-20
TK-7108	B51-8592-10 (This service manual)	REVISED	C, M	X57-6913-01	X54-3460-20

GENERAL / 概述

INTRODUCTION

SCOPE OF THIS MANUAL

This manual is intended for use by experienced technicians familiar with similar types of commercial grade communications equipment. It contains all required service information for the equipment and is current as of this publication date. Changes which may occur after publication are covered by either Service Bulletins or Manual Revisions, which are issued as required.

ORDERING REPLACEMENT PARTS

When ordering replacement parts or equipment information, the full part identification number should be included. This applies to all parts: components, kits, and chassis. If the part number is not known, include the chassis or kit number of which it is a part and a sufficient description of the required component for proper identification.

PERSONAL SAFETY

The following precautions are recommended for personal safety:

- DO NOT transmit if someone is within two feet (0.6 meter) of the antenna.

引言

本手册的范围

本手册是提供给熟悉通信专业并且具有维修经验的技术人员使用的。它包括了维修该设备所需要的全部资料和现行出版日期。在出版后可能发生变动,如果需要,可以参照《维修通报》或《手册修订本》进行补充。

替换零件的订购

当订购替换零件或设备资料时,应注意完整的零件识别号码。所有的零件均有识别号码:元件,组件或机壳。如果不知道零件的号码,为了正确地识别,必须注明此元件所属的机壳或组件的号码,并对元件进行充分的说明。

个人安全

为了个人的安全,请注意下列事项:

- 如果有人在天线两英尺 (0.6 米) 范围之内时, 不要进行发射。

GENERAL / 概述

- DO NOT transmit until all RF connectors are secure and any open connectors are properly terminated.
- SHUT OFF this equipment when near electrical blasting caps or while in an explosive atmosphere.
- All equipment should be properly grounded before power-up for safe operation.
- This equipment should be serviced by only qualified technicians.

PRE-INSTALLATION CONSIDERATIONS

1. UNPACKING

Unpack the radio from its shipping container and check for accessory items. If any item is missing, please contact KENWOOD immediately.

2. LICENSING REQUIREMENTS

Federal regulations require a station license for each radio installation (mobile or base) be obtained by the equipment owner. The licensee is responsible for ensuring transmitter power, frequency, and deviation are within the limits permitted by the station license.

Transmitter adjustments may be performed only by a licensed technician holding an FCC first, second or general class commercial radiotelephone operator's license. There is no license required to install or operate the radio.

3. PRE-INSTALLATION CHECKOUT

3-1. Introduction

Each radio is adjusted and tested before shipment. However, it is recommended that receiver and transmitter operation be checked for proper operation before installation.

3-2. Testing

The radio should be tested complete with all cabling and accessories as they will be connected in the final installation. Transmitter frequency, deviation, and power output should be checked, as should receiver sensitivity, squelch operation, and audio output. Signalling equipment operation should be verified.

4. PLANNING THE INSTALLATION

4-1. General

Inspect the vehicle and determine how and where the radio antenna and accessories will be mounted.

Plan cable runs for protection against pinching or crushing wiring, and radio installation to prevent overheating.

4-2. Antenna

The favored location for an antenna is in the center of a large, flat conductive area, usually at the roof center. The trunk lid is preferred, bond the trunk lid and vehicle chassis using ground straps to ensure the lid is at chassis ground.

4-3. Radio

The universal mount bracket allows the radio to be mounted in a variety of ways. Be sure the mounting surface is adequate to support the radio's weight. Allow sufficient space around the radio for air cooling. Position the radio close enough to the vehicle operator to permit easy access to the controls when driving.

- 在没有认真核实所有射频插头之前或有任何一个脱开的插头没有连接到相应端口上的情况下均不要发射。
- 在电爆管附近或在易燃性气体环境中, 必须关闭电源, 不要操作本设备。
- 为了操作的安全, 在接通电源之前所有设备应该连接地线。
- 本设备只应该由有资格的技术人员进行维修。

安装前条件

1. 开箱

从运输包装中取出本无线电设备并检查附件。如果有任何组件遗失, 请立即与KENWOOD联系。

2. 所需许可证

联邦法规要求设备所有者必须使每一个安装无线电的地点(移动站或基站)获得许可证。持有许可证者必须确保发射功率, 频率以及频偏在许可证的有限允许范围之内。

必须只能由经许可的, 持有FCC一级, 二级或高级商业无线电电话机操作者证书的技术人员进行发射调整。安装或操作。本无线电设备无需许可。

3. 安装前检查

3-1. 说明

在运输之前每一台无线电设备均已调整和测试过。但是, 在安装之前最好检查接收和发射以便操作正确。

3-2. 测试

无线电设备应该按照电缆和附件最终安装时的连接进行完整的测试。应该检查发射频率, 频偏和输出功率, 同样应该检查接收灵敏度, 静噪和音频输出。应该检验信令操作。

4. 安装的步骤

4-1. 概述

检查车辆并确认如何以及在何处安装无线电天线和附件。安排好电缆的位置, 避免挤压或碾碎布线, 同时无线电设备避免过热。

4-2. 天线

天线的最佳位置应该在一个宽阔, 平整导电区域的中心, 通常在车顶的中心。行李箱的盖子更好, 将地线黏结在行李箱的盖子和车辆的外壳上确保行李箱盖子接地。

4-3. 无线电设备

通用安装托架允许以多种方法安装无线电设备。确认安装的表面足以支撑无线电设备的重量。无线电设备的周围留出适当的空间进行散热。将无线电设备尽可能的安装在靠近车辆操作者的位置上, 以便在驾驶时易于控制。

GENERAL / 概述

4-4. DC Power and wiring

1. This radio may be installed in negative ground electrical systems only. Reverse polarity will cause the cable fuse to blow. Check the vehicle ground polarity before installation to prevent wasted time and effort.
2. Connect the positive power lead directly to the vehicle battery positive terminal. Connecting the Positive lead to any other positive voltage source in the vehicle is not recommended.
3. Connect the ground lead directly to the battery negative terminal.
4. The cable provided with the radio is sufficient to handle the maximum radio current demand. If the cable must be extended, be sure the additional wire is sufficient for the current to be carried and length of the added lead.

5. INSTALLATION PLANNING – CONTROL STATIONS

5-1. Antenna system

Control station. The antenna system selection depends on many factors and is beyond the scope of this manual. Your KENWOOD dealer can help you select an antenna system that will best serve your particular needs.

5-2. Radio location

Select a convenient location for your control station radio which is as close as practical to the antenna cable entry point. Secondly, use your system's power supply (which supplies the voltage and current required for your system). Make sure sufficient air can flow around the radio and power supply to allow adequate cooling.

SERVICE

This radio is designed for easy servicing. Refer to the schematic diagrams, printed circuit board views, and alignment procedures contained in this manual.

NOTE

If you do not intend to use the 3.5-mm jack for the external speaker, fit the supplied speaker-jack cap to stop dust and sand from getting in.

4-4. 直流电源和布线

1. 本无线电设备只能被安装在负极接地电子系统中。反向极性将导致电缆保险丝熔断。在安装之前检查车辆的接地极性，避免工作效率低以及浪费时间。
2. 将电源的正极引线直接连接到车载电池的正极端点上。不要将正极引线与其他正极电压连接。
3. 将接地引线直接与电池的负极连接。
4. 与无线电设备一起提供的电缆适用于所需的最大无线电电流。如果电缆必须加长，要确认附加的电线适用于所载的电流和添加引线的长度。

5. 安装步骤-基站

5-1. 天线系统

基站。天线系统的选择取决于许多因素和本手册的范围。用户的KENWOOD销售商可以帮助用户选择最能满足用户特殊要求的天线系统。

5-2. 无线电位置

为用户的基站无线电设备选择一个方便的位置，此位置应尽量靠近天线电缆输入点。其次，使用用户系统的电源（为用户的系统提供所需的电压和电流）。确认无线电设备周围的空气流通顺畅并且足以使电源冷却。

维修服务

为了便于维修本设备，建立了完整的维修服务体系，提供了包括原理图，印刷电路板图和调整步骤在内的资料供参考。

注意事项

3.5mm外部扬声器插孔不用时，请用提供的扬声器插孔帽将其盖上，以防止沙尘进入。

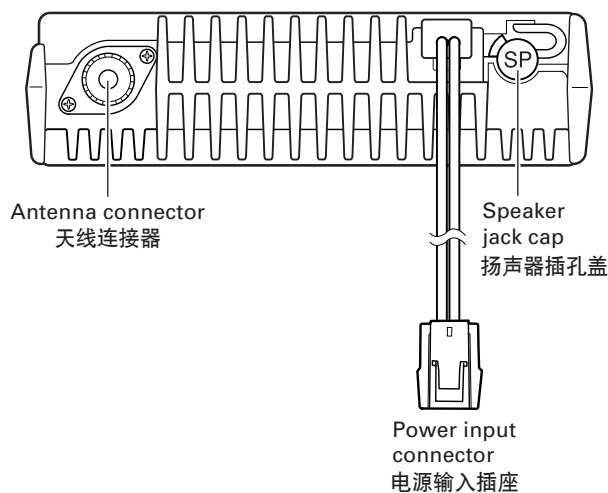

SYSTEM SET-UP / 系统体系

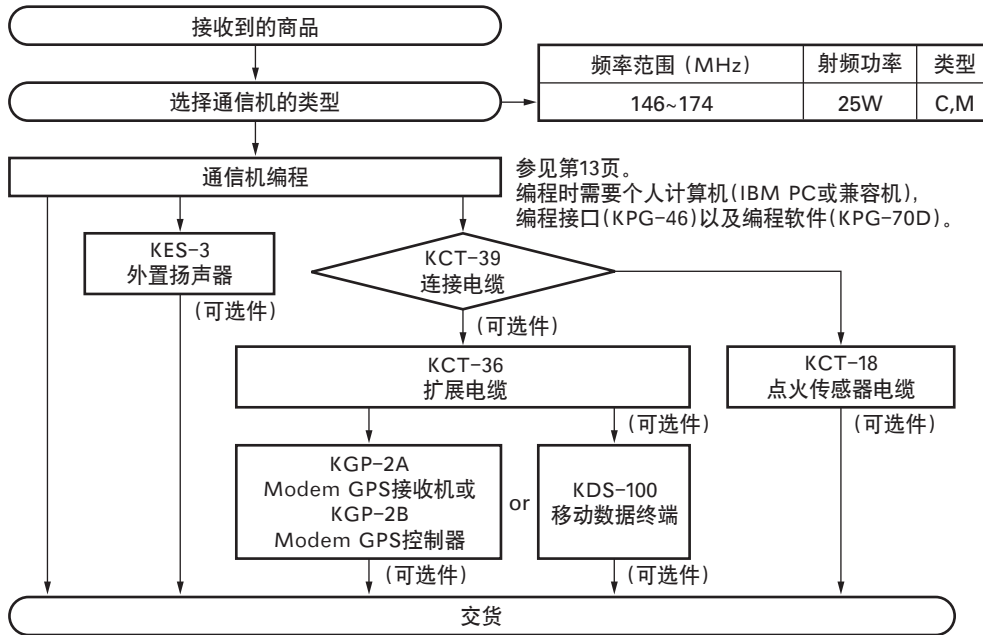
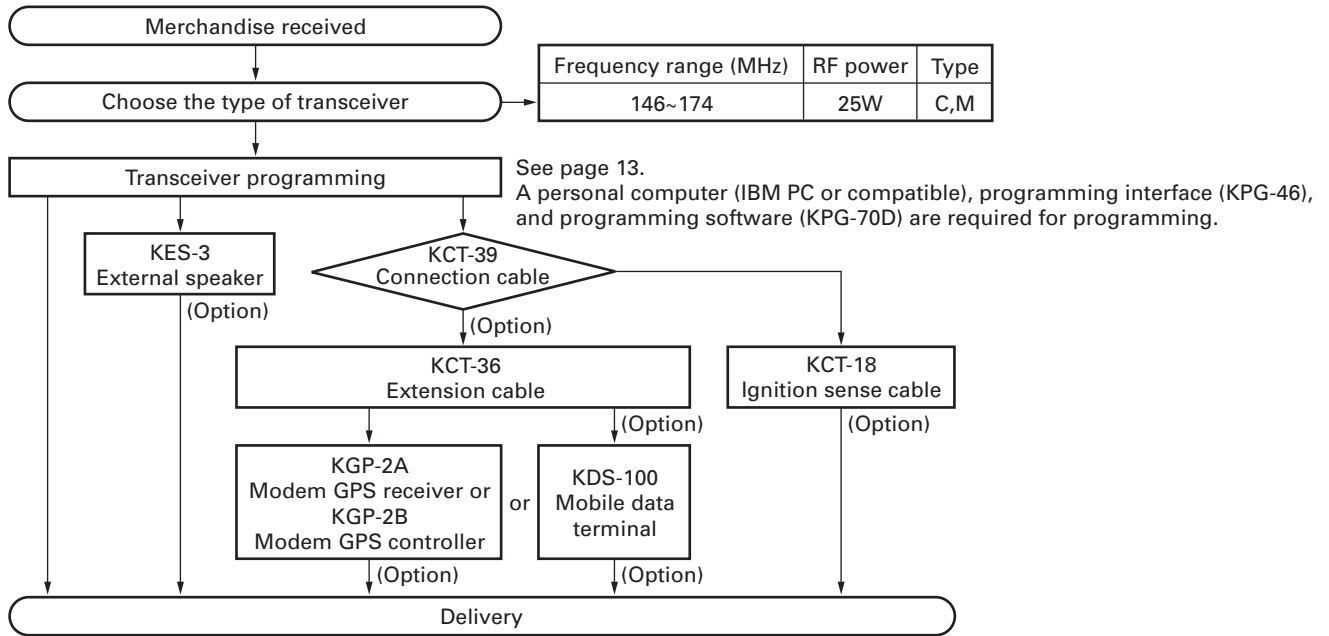

操作特性

1. 控制和功能

1-1. 前面板

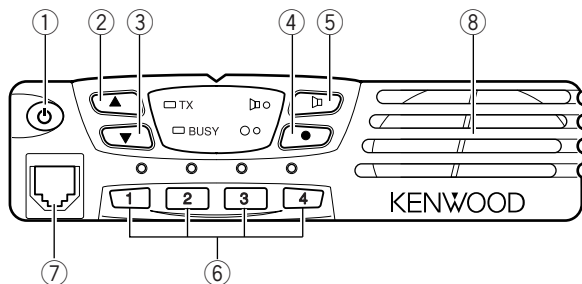

1-2. 麦克风

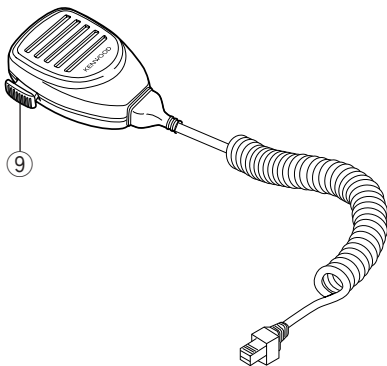

- ① (电源) 开关
按此键可以接通对讲机的电源。按下并且保持大约1秒钟,可以切断对讲机的电源。
- ② ▲ 键
按此键可以升高音量。
- ③ ▼ 键
按此键可以降低音量。
- ④ ● 键
PF (可编程功能) 键。该键的原设置为无 (无功能)。该键可使用的可编程功能如下所示。
- ⑤ ▢ 键
PF (可编程功能) 键。该键的原设置为监听器。该键可使用的其他可编程功能如下所示。
- ⑥ 1/2/3/4 键
按此键可以从1至4选择频道。使用组功能时,按下后可选择5至8的频道。
- ⑦ 麦克风插孔
用于插入麦克风插头。
- ⑧ 扬声器
内置扬声器。
- ⑨ PTT (按下通话) 开关
按下此开关,然后向麦克风说话,呼叫电台。

1-3. 可编程辅助功能

- 紧急报警
- 扫描ON/OFF
- 按键锁定
- 脱网
- 监听器
- 暂时删除
- 无 (无功能)
- 组
- 喇叭提示
- 扫描 + 暂时删除

1-4. 显示

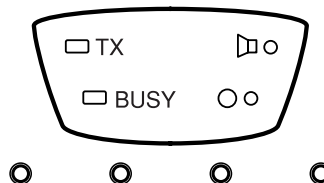

指示灯	说明
□ TX	发射时点亮。
□ BUSY	在当前选择的频道上检测到信号时点亮。
▢	当编程到对应键的功能开启时点亮。
○ ○	当编程到对应键的功能开启时点亮。
○ ○ ○ ○	点亮显示当前选择的频道 (1 ~ 4或5 ~ 8)。

1-5. 后面板

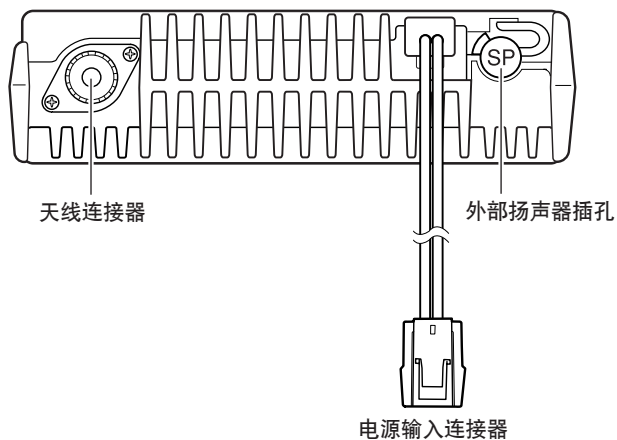

OPERATING FEATURES / 操作特性

2. Operation Features

The TK-7108 is a VHF FM radio designed to operate in conventional format. The programmable features are summarized.

3. Transceiver Controls and Indicators

3-1. Front Panel Controls

All the keys on the front panel are momentary-type push buttons. The functions of these keys are explained below.

- **POWER key**

Transceiver POWER key. When the power is switched off, all the parameters are stored in memory. When the power is switched on again, the transceiver returns to the previous conditions.

- **CHANNEL keys**

- **MONITOR key (Programmable)**

- **● key (Programmable)**

- **VOLUME UP/DOWN key**

When the key is pressed, the volume level is increased/decreased and repeats if held for 200ms or longer.

- **BUSY/TX LED**

The BUSY indicator (Green LED) shows that the channel is in use. The TX indicator (Red LED) shows that you are transmitting.

3-2. Programmable Keys

The FPU (KPG-70D) enables programmable keys to select the following functions.

- Emergency
- Key Lock
- Monitor
- Scan ON/OFF
- Talk Around
- Temporary Delete
- None
- Group
- Horn Alert
- Scan + Temporary Delete

- **Emergency**

Pressing this key for longer than 1 second causes the transceiver to enter the emergency mode. The transceiver jumps to the programmed "Emergency channel" and transmits for 25* seconds.

The transceiver disables mic mute while transmitting. After finishing transmission, the transceiver receives for 5* seconds. The transceiver Mute* the speaker while receiving. Following the above sequence, the transceiver continues to transmit and receive.

* Default value.

2. 操作特性

TK-7108是一种被设计为在常规格式下进行操作的VHF FM无线电设备。可编程特性摘要如下。

3. 车载台控制和指示灯

3-1. 前面板控制

前面板的所有按键均为短瞬型按键。这些按键的功能介绍如下。

- **电源键**

车载台电源按键。当关闭电源时,所有的参数,均被储存在存储器中。当电源再次开启时,车载台回到先前的状态。

- **信道键**

- **监听键 (可编程)**

- **● 键 (可编程)**

- **音量高/低键**

按该键可以增大或减小音量,按下该键并保持200ms以上可连续调节音量。

- **繁忙/发射指示灯**

繁忙指示灯 (绿色) 表示信道正在使用中。发射指示灯 (红色) 表示用户正在进行发射。

3-2. 可编程按键

FPU (KPG-70D) 可以使可编程按键选择下述功能。

- 紧急报警
- 按键锁定
- 监听器
- 扫描ON/OFF
- 脱网
- 暂时删除
- 无
- 组
- 喇叭提示
- 扫描 + 暂时删除

- **紧急报警**

按住此键1秒钟以上将使车载台进入紧急报警模式。车载台将跳到已编程的“紧急报警组和信道”并且发射25*秒钟。

在发射过程中车载台不能保持话筒静音。发送结束后,车载台接收5*秒钟。接收时车台机保持扬声器静音*。按照上述顺序,车载台将连续发射和接收。

* 初始值

OPERATING FEATURES / 操作特性

• Key lock

Pressing this key causes the transceiver to accept entry of only the [Vol Up/Down]*, [Key lock], Microphone [PTT], [Monitor], [Emergency], and [Power] keys.

* Programmable

• Monitor

Used to release signalling (press once) or squelch (press and hold for approximately two seconds) when operating as a conventional. It is also used to reset option signalling.

• Scan ON/OFF

Press this key starts scanning. Pressing this key stops scanning.

• Talk around

Press this key, the transceiver uses the receive frequency and the tone for transmission.

The operator can call the other party directly (without repeater). Press this key again, the talk around function goes off.

• Temporary delete

The "Add" channel contained in the scan sequence, and "Delete" channel is not contained. In the scan mode, this key switches the channel delete temporarily (Press and hold for approximately one second).

When the transceiver is turned off, the transceiver exits the scan or switches the scan function off.

• None

Sounds error operation beep, and no action will occur. Use this function when the transceiver is required to be more simple operated.

• Group

If group has been programmed onto a key, press the Group key to select the second group of channels. While active, the LED beside the key lights. At this time, press a key from 1 to 4 to select a channel from 5 to 8. To return to channels 1 through 4, press the Group key again.

Note : You cannot use the Group function while operating in Emergency mode.

• Horn alert

Horn Alert is a useful feature that will notify you of a received call while you are away from your vehicle. The transceiver is programmed to sound the vehicle horn or some other external alert device (such as the vehicle headlights) when a call is received that has correct signalling.

• Scan + Temporarily delete

To temporarily remove a channel from the Scan list, press and hold this key for approximately one second during Scan, while Scan is paused on the undesired channel, to temporarily remove that channel from the scanning sequence. After switching the Scan function OFF, or switching the transceiver OFF and then ON again, the Scan settings return to normal.

● 按键锁定

按此键使车载台只接收 [音量高/低]*, [按键锁定], 话筒 [通话], [监听器], [紧急报警] 和 [电源] 按键的输入。

* 可编程

● 监听器

当以常规方式操作时用于释放信令 (按一次) 或静噪抑制 (按下并保持约两秒钟)。也用于复位可选信令。

● 扫描ON/OFF

按此键开始扫描。再按此键停止扫描。

● 脱网

按该键, 车载台将使用脱网频率。

使用者可直接呼叫对方 (不需要转发器)。再次按该键将关闭脱网功能。

● 临时删除

“添加”信道包含在扫描序列中, 而“消除”信道不包含在扫描序列中。在扫描模式下, 该键为信道暂时消除开关 (按下并保持约1秒钟)。

当车载台关闭时, 它将退出扫描或关闭扫描功能。

● 无

错误操作beep音响起, 并且无任何变化。当车载台需要更简单操作时使用此功能。

● 组

如果组功能已经编程到某一键, 按下组键选择频道的第二组。本功能开启后, 该键旁的LED指示灯点亮。这时, 按下1至4中的键, 从5至8中选择频道。需要返回到频道1至4时, 再次按下组键。

注释 : 在紧急模式下操作时, 无法使用组功能。

● 喇叭提示

当你离开你的车辆时, 喇叭提示功能较为实用, 如有接收到的呼叫将通知你。适当编程及配置通信机和车辆后, 当接收到带有正确信令的呼叫时, 通信机能够让车辆鸣响喇叭或让其它外部提示设备 (例如车辆前灯) 动作。

● 扫描 + 暂时删除

扫描功能打开时, 可以从扫描序列当中暂时删除不想扫描的信道。当扫描暂停在希望删除的信道上时, 按住此键约1秒钟, 就可以从扫描序列中暂时删除此信道。当关闭扫描后, 或关闭通信机电源再打开后, 扫描序列的设置将恢复到原来的状态。

OPERATING FEATURES / 操作特性

4. Scan Operating

■ SCAN start condition

Two or more channels must be added to all channels that can be scanned. The transceiver must be in normal receive mode (PTT off).

When you activate the key programmed to the scan ON/OFF function, the scan starts. The indicator next to the programmed key LED blinks.

■ Scan stop condition

The scan stops temporarily if the following conditions are satisfied.

- 1) A carrier is detected, then QT/DQT matches on channels for which receive the QT/DQT is set by the programming software.
- 2) A carrier is detected on the channels for which receiving QT/DQT is not set by the programming software or when the monitor (signalling cancel) function is activated.

■ Revert channel

The revert channel is used to transmit during scanning and set by the programming software (KPG-70D).

1) Selected channel

The transceiver reverts to the channel before scanning or the channel that you changed during scan.

2) Selected with talkback

The transceiver reverts to the selected channel prior to scan initiation.

However, if a call is received on a channel other than the selected channel and PTT is pressed before scanning resume, the transceiver "talks back" on the current receive channel.

■ Scan end

When you press the key programmed to the scan function during scan mode, the scan ends.

The indicator next to the programmed key LED turns off.

■ Temporary delete

It is possible to delete channel temporary during scan. When scan stops on unnecessary channel for example by interference of the other party, activate the delete function (for example press and hold the key for approximately one second), then that channel is deleted temporarily and scan restart immediately.

The temporary deleted channels return to pre-set delete/add channels, when the transceiver is turned off or the scan function is switched off.

5. Details of Features

■ Time-out timer

The time-out timer can be programmed in 30 seconds increments from 30 seconds to five minutes and off. If the transmitter is transmitted continuously for longer than the programmed time, the transmitter is disabled and a warning tone sounds while the PTT button is held down. The warning tone stops when the PTT button is released.

4. 扫描操作

■扫描开始条件

可扫描信道中必须至少添加两个以上的信道。车载台必须处于一般接收模式 (PTT关闭)。

当启动扫描ON/OFF 功能键时开始扫描, 该键旁边的指示灯会闪烁。

■扫描开始条件

如果下述条件具备, 则扫描临时停止。

- 1) 检测到载波, QT/DQT与编程软件设定的接收QT/DQT的信道上相匹配。
- 2) 在没有由编程软件设定为接收QT/DQT的信道上检测到载波时, 或者在启动了监听 (信令取消) 功能时。

■回复信道

回复信道用于在扫描过程中发射, 并且通过编程软件 (KPG-70D) 设定。

1) 选择信道

车载台回复到扫描之前的信道或用户在扫描过程中改变的信道。

2) 选择带有回应的信道

在扫描开始之前, 车载台回到所选信道上。

但是, 在所选信道之外的信道上收到呼叫并且在继续扫描前按下了PTT键时, 车载台将在当前接收信道上“回话”。

■扫描结束

在扫描模式中按扫描功能键时, 扫描停止。

该键旁边的指示灯关闭。

■临时删除

可以在扫描进行中暂时消除信道。如果扫描停在不需要的信道 (例如对方的干扰) 上, 则可启动消除键 (例如按该键并保持约1秒钟), 该信道将被暂时消除并立即重新启动扫描。

当收发机关闭或扫描功能关闭时, 暂时删除的信道将返回到预设的消除/添加信道中。

5. 详细功能

■超时计时器

可以以30秒为增量设置超时计时器, 可设置范围为30秒到5分钟或关闭。当发射器连续发射时间超过了预设时间时, 发射器将被禁用并且在按住PTT键时鸣响警告音。放开PTT键后警告音停止。

OPERATING FEATURES / 操作特性

■ PTT ID

PTT ID provides a DTMF ANI or MSK ID to be sent with every time PTT (connect ID at beginning of transmission, disconnect ID at end of transmission, or both).

You can program PTT ID “on” or “off” for each group channel (DTMF). The contents of ID are programmed for each transceiver.

The transceiver is capable to have ID. The format is DTMF. The timing that the transceiver sends ID is programmable.

BOT : Connect ID is sent on beginning of transmission.

EOT : Disconnect ID is sent on end of transmission.

Both : Connect ID is sent on beginning of transmission and disconnect ID is sent on end of transmission.

There is also “PTT ID” setting for each channel.

■ Off hook decode

If the Off hook decode function has been enabled, removing and replacing the microphone on the hook has no effect for decoding QT/DQT and option signalling.

■ “TOT” pre-alert

The transceiver has “TOT” pre-alert timer. This parameter selects the time at which the transceiver generates “TOT” pre-alert tone before “TOT” is expired.

“TOT” will be expired when the selected time passes from a TOT pre-alert tone.

■ “TOT” re-key time

The transceiver has “TOT” re-key timer. This timer is the time you can not transmit after “TOT” exceeded. After “TOT” re-key time expired you can transmit again.

■ “TOT” reset time

The transceiver has “TOT” reset timer. This timer is the minimum wait time allowed during a transmission that will reset the “TOT” count.

“TOT” reset time causes the “TOT” to continue even after PTT is released unless the “TOT” reset timer has expired.

■ Clear to transpond

The transceiver waits the transpond of DTMF if channel is busy until channel open. This feature prevents the interference to other party.

6. Option Signalling (DTMF)

Built-in DTMF decoder is available for option signalling.

It is possible to use individual call, group call, Stun.

If the option signalling matches, a predetermined action will occur.

If option signalling matches on a channel is set up with option signalling, the channel LED will flash and option signalling will be released. The transpond or alert tone will sound.

While option signalling matches (or if option signalling is deactivated when you are transmitting), you can mute or unmute QT/DQT/Carrier.

■ PTT ID

PTT ID功能提供在每次按PTT键时发送DTMF ANI或MSK ID信号 (在发射开始时的connect ID, 在发射结束时的disconnect ID, 或两者都有)。

你可以分别编程各组信道 (DTMF) 的PTT ID功能为“on”开或“off”关。但对于ID的内容, 同一台通信机是一致的。

通信机可以具有ID。其格式为DTMF。通信机发送ID的时间是可以编程的。

BOT : 在发射开始时, 发送Connect ID。

EOT : 在发射结束时, 发送Disconnect ID。

Both : 在发射开始时发送Connect ID, 在发射结束时发送Disconnect ID。

每个信道都可以进行“PTT ID”功能的设置。

■ 挂断解码

如果挂断解码功能生效, 则接通时消除和更换话筒对于QT/DQT解码和可选信令无效。

■ “TOT”预先告警

车载台具有一个“TOT”预先告警计时器。在“TOT”终止之前, 此参数设定在收发机产生“TOT”预先告警音时的时间。

当TOT 预先告警音发出开始时“TOT”将终止。

■ “TOT”再按键时间

车载台具有一个“TOT”再按键定时器。在“TOT”时间超出之前, 此定时器是用户不能发射的时间。在“TOT”再按键时间终止后, 用户可以再发射。

■ “TOT”复位时间

车载台具有一个“TOT”复位计时器。在复位“TOT”计数的发射过程中, 此计时器是最小允许等待时间。

除非“TOT”复位计时器终止, 否则即使松开PTT键之后, “TOT”复位时间也使“TOT”继续进行。

■ 加强自动应答

如果信道直到打开均繁忙, 车载台将等待DTMF应答。此特性防止干扰到对方。

6. 可选信令 (DTMF)

内置DTMF 解码器对可选信令有效。

使用单呼, 组呼, 遥毙。

如果可选信令相匹配, 则触发预定的操作。

如果可选信令在使用可选信令设置的信道上相匹配, 信道指示灯将闪烁并且可选信令将被取消。应答或告警将发出声音。

当可选信令相匹配时 (或如果当用户发射时可选信令被抑制时), 用户可以使QT/DQT载波静音或非静音。

OPERATING FEATURES / 操作特性

■ SP Unmute

You can select the type of SP Unmute system for each channel. The selection is as follows.

Carrier, QT/DQT:

Channel with this option will not check ID Code in order to open its speaker.

Carrier+DTMF, QT/DQT+DTMF:

Channel that is set with this option will have to check for ID Code in order to open its speaker.

Default:

Carrier, QT/DQT.

SP unmute	Channel setting		RX condition	Speaker condition
	QT/DQT	DTMF		
Carrier	None	None	Carrier	Sounds
		Yes	Carrier	Sounds
			Carrier+DTMF	Sounds
Carrier+DTMF	None	Yes	Carrier	Not Sounds
			Carrier+DTMF	Sounds
QT/DQT	Yes	None	Carrier	Not Sounds
			Carrier+QT/DQT	Sounds
		Yes	Carrier	Not Sounds
			Carrier+QT/DQT	Sounds
			Carrier+QT/DQT+DTMF	Sounds
			Carrier+DTMF	Not Sounds
QT/DQT+DTMF	Yes	Yes	Carrier	Not Sounds
			Carrier+QT/DQT	Not Sounds
			Carrier+QT/DQT+DTMF	Sounds
			Carrier+DTMF	Not Sounds

Note :

When QT/DQT is not used, QT/DQT and QT/DQT+DTMF can not be selected.

When DTMF is not used, Carrier+DTMF and QT/DQT+DTMF can not be selected.

■ Auto Reset

If option signalling matches a group set up with option signalling, option signalling is released. After matching option signalling, option signalling will temporarily reset automatically.

■ Stun

If the stun code matches, a predetermined action will occur. Whether option signalling is activated or not, when stun matches on any channel, the transceiver will become TX inhibited or TX/RX inhibited. While stun is active, if the stun code + “#” code is received, stun will deactivate.

When stun matches, transpond will function. Alert will not be output.

■ 扬声器监听

可以为各信道选择如下扬声器监听系统类型。

载波, QT/DQT :

设定为该选项的信道打开其扬声器时将不检查ID代码。

载波 + DTMF, QT/DQT + DTMF :

设定为该选项的信道打开其扬声器时必须检查ID代码。

初始值 :

载波, QT/DQT。

扬声器监听	信道设置		RX条件	扬声器状态
	QT/DQT	DTMF		
载波	无	无	载波	噪音
		是	载波	噪音
			载波+DTMF	噪音
载波+DTMF	无	是	载波	无噪音
			载波+DTMF	噪音
QT/DQT	是	无	载波	无噪音
			载波+QT/DQT	噪音
		是	载波	无噪音
			载波+QT/DQT	噪音
			载波+QT/DQT+DTMF	噪音
			载波+DTMF	无噪音
QT/DQT+DTMF	是	是	载波	无噪音
			载波+QT/DQT	无噪音
			载波+QT/DQT+DTMF	噪音
			载波+DTMF	无噪音

注释 :

不使用QT/DQ 时, 不能选定QT/DQT及QT/DQT+DTMF。
不使用DTMF时, 不能选定载波+DTMF及QT/DQT+DTMF。

■ 自动复位

如果可选信令与使用可选信令设置的组相匹配, 可选信令被取消。可选信令匹配之后, 可选信令将临时自动复位。

■ 遥毙

遥毙代码匹配时将执行预定操作。当遥毙在任何信道匹配时, 无论可选信令启用与否, 车台机都将进入发射禁止或发射/接收禁止。当遥毙启用时, 收到遥毙代码 + “#” 代码时将禁用遥毙。

当遥毙匹配时应答功能有效。将不输出告警。

7. Audible User Feedback Tones

The transceiver outputs various combinations of tones to notify the user of the transceiver operating state.

Refer to the help file on the KPG-70D, regarding the functions that are not listed below.

■ Stun on tone

When a stun code is received, transpond tone sounds.

■ Stun off tone

When a stun release code is received, transpond tone sounds.

■ Group call tone

Sounds when a group call with the correct DTMF option signalling is received, repeats 7 times. You can select yes or no in the Alert tone level setting.

■ Individual call tone

Sounds when an individual call with the correct DTMF option signalling is received. You can select yes or no in the Alert tone level setting.

■ Key input error tone

Sounds when a key is pressed but that key cannot be used. You can select yes or no for the optional feature's warning tone.

■ Transpond tone

Sounds when an individual call with the correct DTMF option signalling is received. For group calls, only the group tone will sound, not the transpond tone.

■ Pre alert tone

Sounds prior to the TOT TX inhibit activation. If TOT pre alert is set, the tone sounds at the amount of time programmed, before the TOT expires (TOT time - TOT pre alert time = Pre alert tone sounding time). You can select yes or no for the optional feature's warning tone.

■ Transmit protection

The power module is protected against heat while transmitting by making the radio cuts down TX power when the temperature of the power module becomes higher than reference. After that, if the temperature continue to rise, transmission is stopped. The power module is also protected against over voltage by having the radio to check that the voltage of power supply connected to the radio is not higher than about 17V when the radio is turned on, otherwise it can not transmit. In both cases when transmission is stopped, a beep will continue to sound until the PTT key is released.

7. 用户反馈提示音

车载台发出各种提示音以提示用户车载台的操作状态。

有关以下没有列出的功能,请参考KPG-70D上的帮助文件。

■ 遥毙开启提示音

当收到了遥毙代码时鸣响应答音。

■ 遥毙关闭提示音

当收到了遥毙取消代码时鸣响应答音。

■ 组呼提示音

当接收到带有正确的DTMF可选信令的组呼时发出提示音,并重复7次。在告警音电平设定中可以选择是或否。

■ 单呼提示音

当接收到带有正确的DTMF可选信令的单呼时发出提示音。在告警音电平设定中可以选择是或否。

■ 按键输入错误提示音

当按下下一个按键但不能使用此按键时发出提示音。用户可以选择要或不要此可选特性的警告提示音。

■ 应答提示音

当接收到带有正确的DTMF可选信令的单呼时发出提示音。关于组呼,只发出组提示音,不发出应答提示音。

■ 预先告警提示音

向TOT发射禁止发出优先提示音。如果设定了TOT预先告警,在TOT终止之前,在编制的时间发出提示音 (TOT时间 - TOT预先告警时间 = 发出预先告警提示音的时间)。用户可以选择要或不要此可选特性的警告提示音。

■ 发射保护

功率模块在发射时具有防热保护。当功率模块的温度高于参考值时,通信机将切断TX电源。此后,如果温度不断上升,发射就会停止。功率模块也具有过电压保护。当电源打开时,通信机将检测与收音机连接的供电压是否不超过17伏电压,否则的话,功率模块将无法发射。在这两种情况下,当发射停止时,将会有持续的嘟嘟声直到PTT键被断开为止。

REALIGNMENT / 模式组合

1. Modes

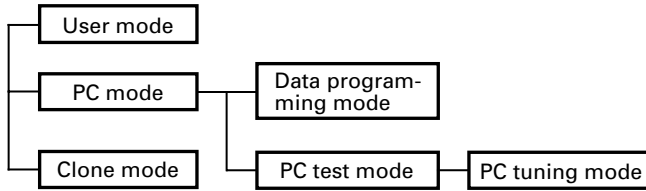

Mode	Function
User mode	For normal use.
PC mode	Used for communication between the radio and PC (IBM compatible).
Data programming mode	Used to read and write frequency data and other features to and from the radio.
PC test mode	Used to check the radio using the PC. This feature is included in the FPU.
PC tuning mode	Used to tune the radio using the PC.
Clone mode	Used to transfer programming data from one radio to another.

2. How to Enter Each Mode

Mode	Operation
User mode	Power ON
PC mode	Received commands from PC
Clone mode	[1]+Power ON (Two seconds)

3. PC Mode

3-1. Preface

The TK-7108 transceiver is programmed using a personal computer, a programming interface (KPG-46) and programming software (KPG-70D).

The programming software can be used with an IBM PC or compatible. Figure 1 shows the setup of an IBM PC for programming.

1. 模式

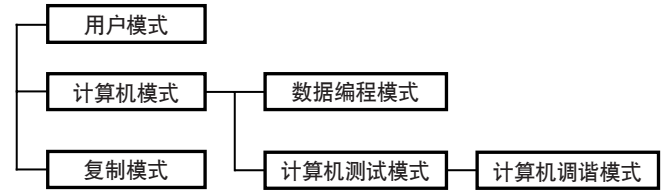

模式	功能
用户模式	一般使用。
计算机模式	用于车载台与计算机 (IBM兼容机) 之间的通信。
数据编程模式	用于阅读和写入频率数据以及其他功能。
计算机测试模式	用于使用计算机检测。此特性包括在FPU内。
计算机调谐模式	用来利用计算机调谐通信机。
复制模式	用于从一个车载台编程数据复制到另一个车载台。

2. 如何进入每一种模式

模式	操作
用户模式	接通电源
计算机模式	从计算机接收指令
复制模式	[1] + 通电 (2秒钟)

3. 计算机模式

3-1. 前言

TK-7108车台机使用计算机, 编程电缆 (KPG-46) 和编程软件 (KPG-70D) 进行编程。

IBM计算机或兼容机可以使用编程软件。图1显示IBM计算机编程的设置。

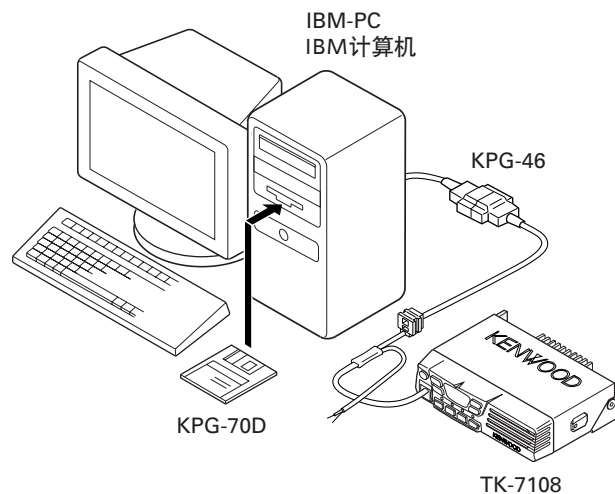

Fig. 1 / 图1

3-2. Connection Procedure

1. Connect the TK-7108 to the personal computer with the interface cable.
2. When the Power is switched on, user mode can be entered immediately. When the PC sends a command, the radio enters PC mode.
When data is transmitted from transceiver, the red LED blink.
When data is received by the transceiver, the green LED blink.
In the PC mode, 4CH LEDs, [MON] LED and [●] LED are turned on.

Notes :

- The data stored in the personal computer must match model type when it is written into the EEPROM.
- Attach the interface cable, then change the TK-7108 to PC mode.

3-3. KPG-46 Description

(PC programming interface cable : Option)

The KPG-46 is required to interface the TK-7108 to the computer. It has a circuit in its D-subconnector (25-pin) case that converts the RS-232C logic level to the TTL level.

The KPG-46 connects the modular microphone jack of the TK-7108 to the computers RS-232C serial port.

3-4. Programming Software Description

The KPG-70D programming disk is supplied in 3-1/2" disk format. The software on this disk allows a user to program TK-7108 radio via a programming interface cable (KPG-46).

3-5. Programming With IBM PC

If data is transferred to the transceiver from an IBM PC with the KPG-70D, the destination data (basic radio information) for each set can be modified.

4. Clone Mode

Programming data can be transferred from one radio to another by connecting them via their modular microphone jacks. The operation is as follows (the transmit radio is the master and the receive radio is the slave).

Note :

- Clone mode should enabled.
1. Turn the master TK-7108 power ON with the [1] key held down. The TK-7108 [●] LED is turned on.
 2. Power on the slave TK-7108.
 3. Connect the cloning cable (No. E30-3382-05) to the modular microphone jacks on the master and slave.
 4. Press the [●] key on the master TK-7108 transceiver. The data of the master is sent to the slave. While the master is sending data, [TX] LED blinked. While the slave is receiving the data, 4 LEDs, [MON] LED, [●] LED are turned on and [BUSY] LED blinked. When cloning of data is completed, the master [TX] LED turned off, and the slave automatically operates in the User mode. The slave can then be operated by the same program as the master.
 5. The other slave can be continuously cloned. Carry out the operation in step 2 to 4.

3-2. 连接步骤

1. 使用编程电缆将TK-7108与计算机连接。
2. 当接通电源时,可以立即进入用户模式。当计算机发出一个指令时,车载台进入计算机编程模式。
从车载台发射数据时,红色指示灯闪烁。
当通过车载台接收数据时,绿色指示灯闪烁。
在计算机模式下,4个信道指示灯,[MON]指示灯及[●]指示灯亮。

注释 :

- 存储在计算机中的数据必须与写入EEPROM的格式相匹配。
- 连接编程电缆,然后将TK-7108改变为计算机编程模式。

3-3. KPG-46说明

(计算机编程电缆 : 可选件)

KPG-46用于将TK-7108与计算机连接。在其D型副插座(25芯)中有一个电平转换电路,此电路可以把RS-232C逻辑电平转换为TTL电平。

KPG-46将TK-7108的话筒插座与计算机的RS-232C串行口连接。

3-4. 编程软件说明

KPG-70D编程软盘是一张3-1/2"软盘。软盘内的软件允许用户经由编程电缆(KPG-46)对TK-7108进行编程设定。

3-5. 使用IBM计算机编程

如果从使用KPG-70D磁盘的IBM计算机将数据发送到车载台,设定的目的数据(通信机的基本参数)均可被修改。

4. 复制模式

可以利用标准话筒插孔连接从一台通信机向另一台通信机传送编程数据。按照下述步骤操作(发射方车载台为主机,接收方车载台为子机)。

注释 :

- 启用复制模式。
1. 按住[1]键打开主TK-7108的电源,TK-7108的[●]指示灯亮。
 2. 开启子机TK-7108的电源。
 3. 将数据复制电缆(No.E30-3382-05)连接到主机及从属机的标准话筒插孔。
 4. 按主TK-7108通信机的[●]键。主机的数据将发送到从属机。主机发送数据时[TX]指示灯闪烁。从属机接收数据时4个指示灯,[MON]指示灯及[●]指示灯亮,[BUSY]指示灯闪烁。数据复制完成后,主机的[TX]指示灯关闭,从属机自动运行于用户模式。之后,从属机即可由与主机相同的程序操作。
 5. 另一台子机可以继续复制。进行步骤2到4的操作。

REALIGNMENT / 模式组合

4-1. Adding the data password

If the data password is set in the optional feature menu, you must enter the password (Master transceiver) to activate a clone mode.

you can use 1, 2, 3, and 4 to configure the password. The maximum length of the password is 10 digits.

1. [1]+Power ON.
2. [1]~[4] LED, and MON LED are turned ON.
3. Enter the password using [1]~[4] keys.
4. Press [MON] key.
5. If the password matches, the transceiver enters a clone mode. Otherwise, transceiver beeps and returns to the password input mode.

4-1. 添加数据密码

如果在特性选择菜单中设定了密码,则在启动复制模式时必须输入该密码(主机)。

密码可以使用数字1, 2, 3, 4, 密码的最大长度为10个数字。

1. [1] + 电源接通。
2. [1] ~ [4] 指示灯, MON指示灯亮。
3. 使用键 [1] ~ [4] 输入密码。
4. 按 [MON] 键。
5. 如果密码相符, 车载台将进入复制模式, 否则, 车载台将发出蜂鸣音并回到密码输入模式。

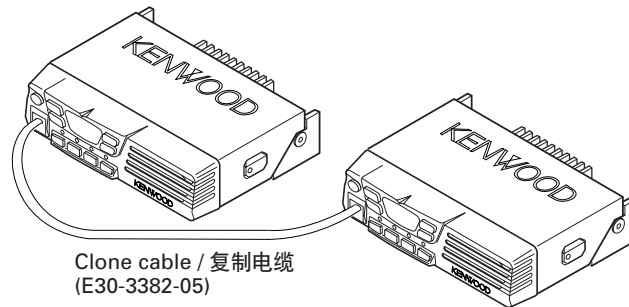
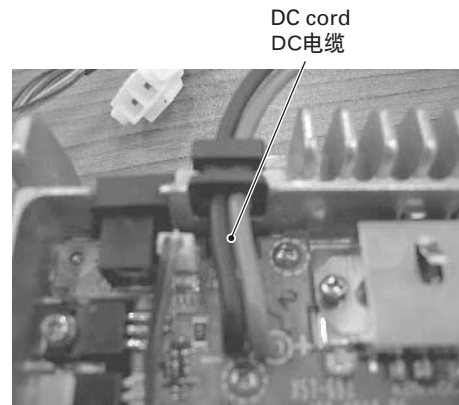
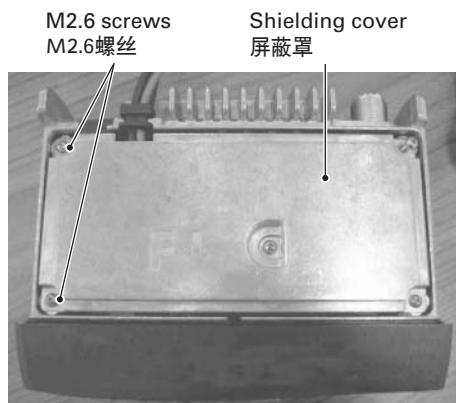

Fig. 2 / 图2

5. Accessory Connection Cable / 连接电缆 (KCT-39)

1. Unscrew the five M2.6 screws (N87-2614-46), then remove the shielding cover (F10-2491-03).
1. 请卸下5个M2.6螺丝 (N87-2614-46), 然后再卸下屏蔽罩 (F10-2491-03)。

2. Lift the DC cord (E30-3448-05) and remove the cushion (G13-2003-04) from the chassis.
2. 抬起DC电缆 (E30-3448-05), 从机架上卸下缓冲垫 (G13-2003-04)。



REALIGNMENT / 模式组合

3. Attach a new cushion (G13-1960-08) to the DC bush.
3. 把新的缓冲垫 (G13-1960-08) 装到DC衬套上。

Cushion / 缓冲垫



4. Place the KCT-39 sumi tube along the chassis and insert the cable tie into the TX-RX PCB slot, as shown in the diagram below.
4. 沿着底架上放上KCT-39 Sumi Tube套管, 然后如下图所示把电缆线卡插入到TX-RX PCB槽。

Insert the cable tie into the slot here
把电缆线卡插入到此槽内

KCT-39 sumi tube
KCT-39 Sumi Tube套管

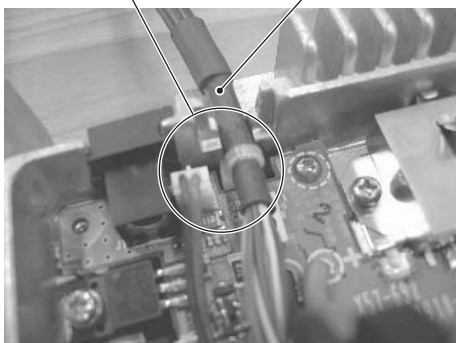

5. Align the KCT-39 cable to the left side of the DC cord, then place the DC cord back into its slot along the chassis (over the top of the KCT-39 sumi tube).
5. 把KCT-39电缆定位于DC电缆左侧, 然后架把DC电缆放回机架的槽内 (在KCT-39 Sumi Tube套管之上)。

In this direction / 在此方向

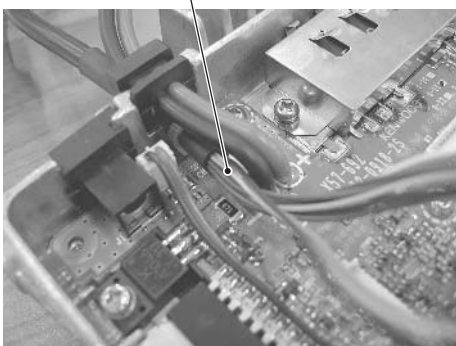

6. Twist the large grouping of wires of the KCT-39 cable twice, then connect it to Terminal A of the PCB. Connect the remaining grouping of wires of the KCT-39 cable to Terminal B.
6. KCT-39电缆的其中线多的一股扭绞两圈, 然后把线连接到PCB板的终端接线座A上。连其余的KCT-39电缆的另一股线到终端接线座B上。

Terminal A
终端接线座A

Terminal B
终端接线座B

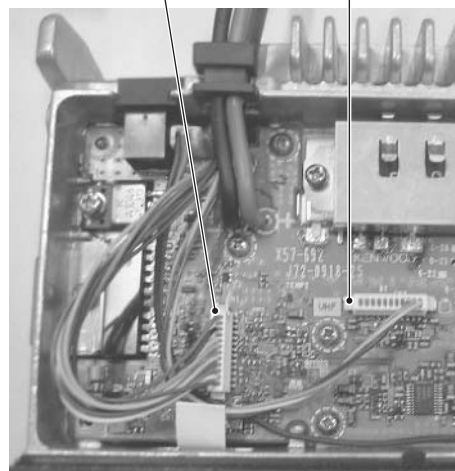

7. Align the terminal B KCT-39 cable underneath the terminal A cable align the speaker cable (T07-1082-05) below both KCT-39 cables.
7. 调整终端接线座B的KCT-39电缆使之在终端接线座A的电缆线的下面, 把扬声器电缆 (T07-1082-05) 调整到KCT-39电缆下面。

In this direction
在此方向

Speaker cable
扬声器电缆

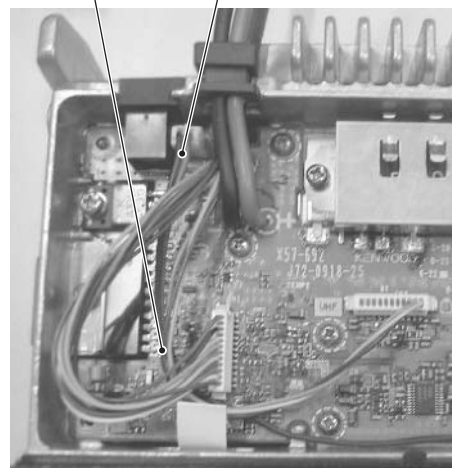

REALIGNMENT / 模式组合

- Align all cable to the left side so as to avoid the Power Module Area. Mount the shielding cover and secure it with the five M2.6 screws.
- 把所有的电缆调整到左侧, 以避免功率模块区域。装上屏蔽罩并用5个M2.6螺丝拧紧固定。

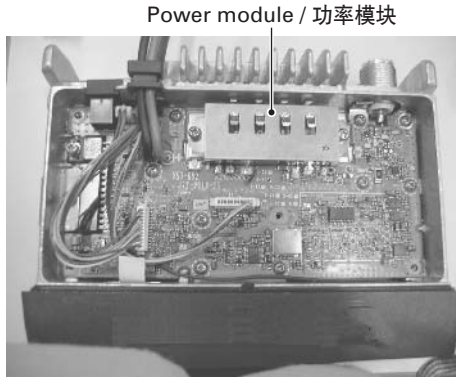

- After everything has been properly mounted, the KCT-39 sumi tube should look similar to that as shown in the diagram below.
- 以上均适当地装配完毕之后, KCT-39 Sumi Tube套管将如下图所示被安装。

Exterior back view of KCT-39
KCT-39外观后视图

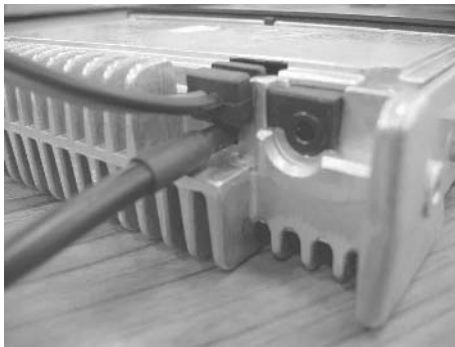

- Connect the KCT-39 to the external accessory by inserting the crimp terminal (1) into the square plug (2), both of which are supplied with the KCT-39.
- 将线夹(1)插入方形插头(2)来连接KCT-39和外部设备, 其两者均随KCT-39提供。

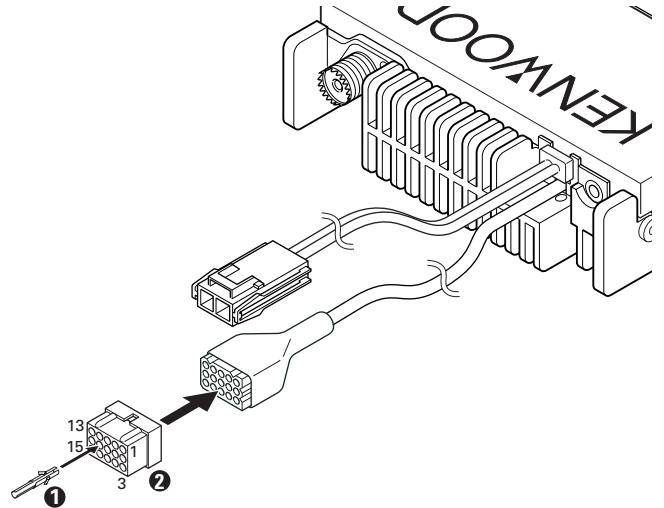
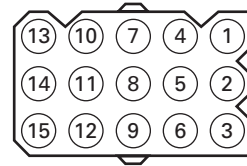

Fig. 3 / 图3

■ Accessory Port Function / 附件端口功能



No.	Color	Internal connector	Name	号	色	内部连接器	名称
1	Red	CN2-1	SB	1	赤	CN2-1	SB
2	Pink	CN3-1	IGN	2	桃	CN3-1	IGN
3	Black	CN2-3	GND	3	黑	CN2-3	GND
4	Brown	CN3-3	DETO	4	茶	CN3-3	DETO
5	Orange	CN3-2	DATA1	5	橙	CN3-2	DATA1
6	Yellow	CN2-8	FNC4	6	黄	CN2-8	FNC4
7	Green	CN2-7	FNC3	7	绿	CN2-7	FNC3
8	Blue	CN2-9	FNC5	8	青	CN2-9	FNC5
9	Purple	CN2-12	FNC8	9	紫	CN2-12	FNC8
10	Gray	CN2-10	FNC6	10	灰	CN2-10	FNC6
11	White	CN2-11	FNC7	11	白	CN2-11	FNC7
12	NC	NC		12	NC	NC	
13	NC	NC		13	NC	NC	
14	Sky blue	CN2-6	FNC2	14	空	CN2-6	FNC2
15	Turquoise	CN2-5	FNC1	15	青绿	CN2-5	FNC1

REALIGNMENT / 模式组合

6. Ignition Sense Cable (KCT-18)

The KCT-18 is an optional cable for enabling the ignition function. The ignition function lets you turn the power to the transceiver on and off with the car ignition key.

6-2. Connecting the KCT-18 to the Transceiver

1. Install the KCT-39 in the transceiver. (See the KCT-39 section)
2. Insert the KCT-18 lead terminal (❶) into pin 2 of the KCT-39 (❷).

6. 点火传感器电缆 (KCT-18)

KCT-18是用于点火功能的选件电缆。点火功能可以使得你用汽车点火钥匙来开启和关闭通信机的电源。

6-2. 把KCT-18连接到通信机

1. 在通信机上安装KCT-39。(参见KCT-39部分)
2. 把KCT-18线夹(❶)插到KCT-39(❷)的引脚2上。

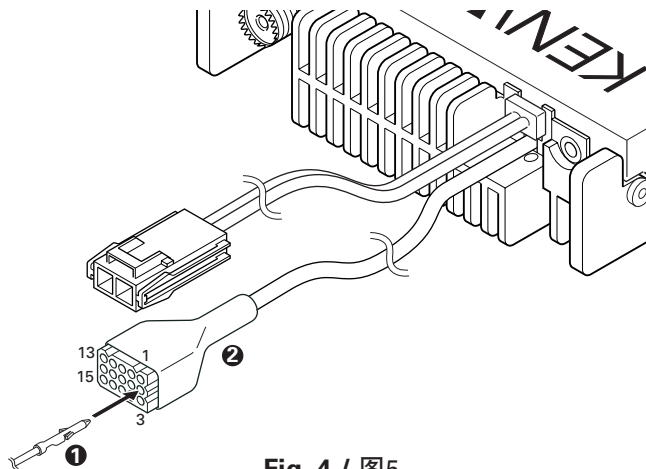

Fig. 4 / 图5

6-3. Modifying the Transceiver

Modify the transceiver as follows to turn the power on and off with the ignition key.

1. Remove the resistor R71 of the TX-RX unit.

■ Setting With the KPG-70D

Select "External Devices" from the "Edit" menu and enable the "Ignition Sense".

6-3. 改装通信机

按照下述方法改装通信机以便使用汽车点火钥匙开启和关闭通信机电源。

1. 卸下TX-RX单元的电阻器R71。

■ 用KPG-70D进行设置

在“编辑”菜单上选择“外部设备”，然后启动“点火传感器”。

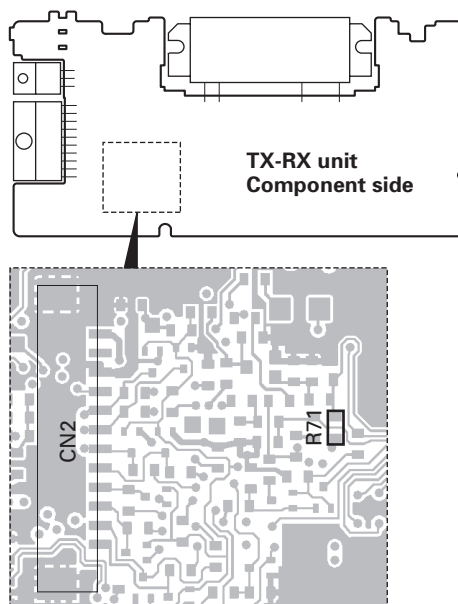

Fig. 5 / 图5

INSTALLATION / 安装

1. Optional Board

1-1. Voice Scrambler Board Connection

■ Modification

1. Remove the cabinet and shielding cover from the transceiver.
2. Delete R202 and R267 on the TX-RX unit.

1. 选件板

1-1. 语音扰频器板的连接

■ 改装

1. 从通信机上卸下机壳和屏蔽罩。
2. 卸下TX-RX单元上的R202和R267。

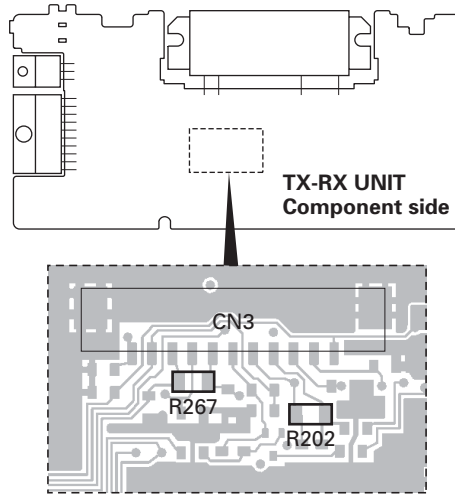

Fig. 1 / 图1

■ Connection

The functions of pins of CN2 and CN3 on the TX-RX unit are shown in the TERMINAL FUNCTION section (page 52).

■ 连接

有关TX-RX单元的CN2和CN3引脚的功能请参阅端子功能部分 (第53页)。

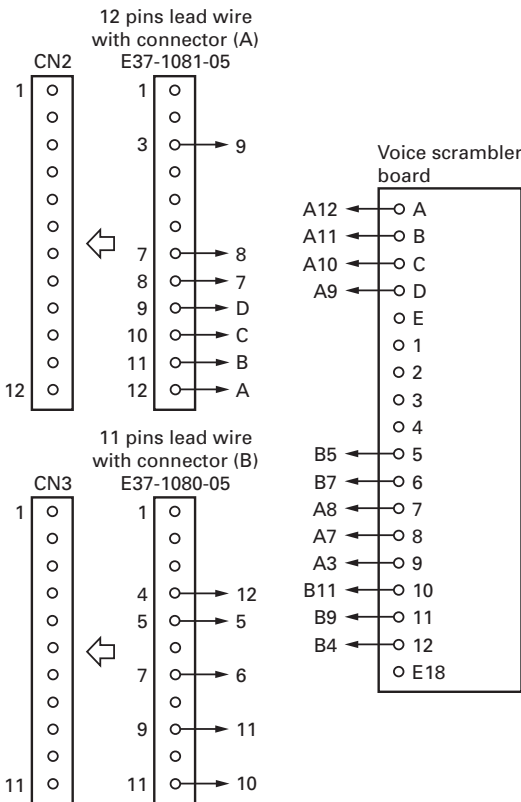

Fig. 2



图2

INSTALLATION / 安装

■ Pins Connection

Voice scrambler functions	12 pins lead wire with connector (A)	11 pins lead wire with connector (B)
A	A-12	-
B	A-11	-
C	A-10	-
D	A-9	-
5	-	B-5
6	-	B-7
7	A-8	-
8	A-7	-
9	A-3	-
10	-	B-11
11	-	B-9
12	-	B-4

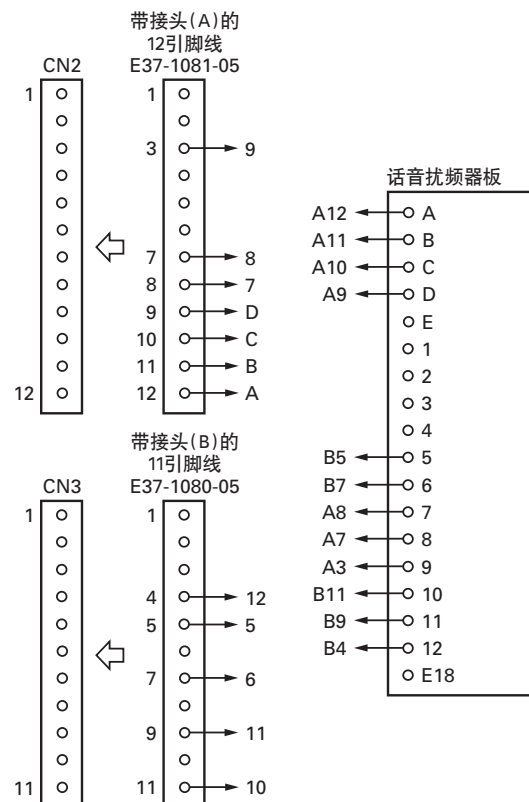
■ 引脚连接

语音扰频器功能	带接头(A)的12引脚线	带接头(B)的11引脚线
A	A-12	-
B	A-11	-
C	A-10	-
D	A-9	-
5	-	B-5
6	-	B-7
7	A-8	-
8	A-7	-
9	A-3	-
10	-	B-11
11	-	B-9
12	-	B-4

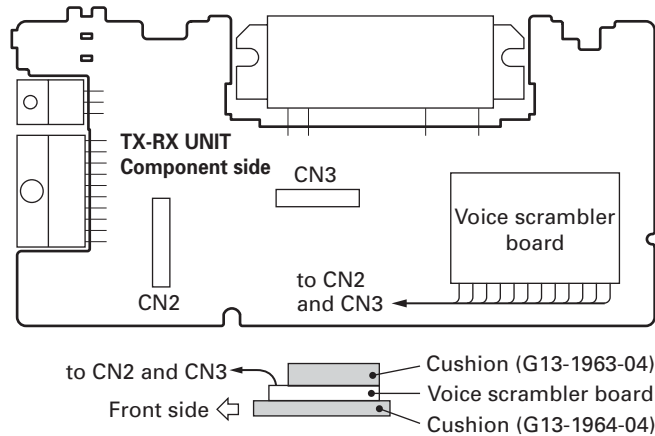

Fig. 3 / 图3

■ Setting With the KPG-70D

Select "External Devices" from the "Edit" menu and set the "Scrambler".

Note :

The voice scrambler board is connected subsequent to the de-emphasis circuit.

■ 用KPG-70D进行设置

在“编辑”菜单上选择“外部设备”，然后启动“扰频器”。

注意：

语音扰频器板是连接在去加重电路的后面。

INSTALLATION / 安装

2. SmarTrunk

1. Unscrew the five M2.6 screws (N87-2614-46), then remove the shielding cover (F10-2491-03).

1. 请卸下5个M2.6螺丝 (N87-2614-46), 然后再卸下屏蔽罩 (F10-2491-03)。

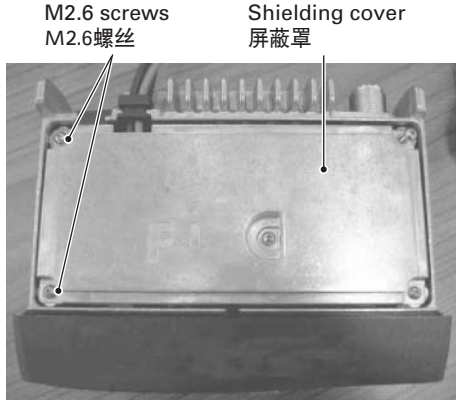

2. The SmarTrunk Board is to be mounted in the silk-screened area.

2. SmarTrunk板是安装在丝网印刷电路区域。



3. Adhere one side of the 27 x 17.5 x 1mm cushion G (G13-2005-04) to the underside of the ST-909.

3. 把27 x 17.5 x 1mm缓冲垫G (G13-2005-04) 的一面粘附到ST-909的下侧。

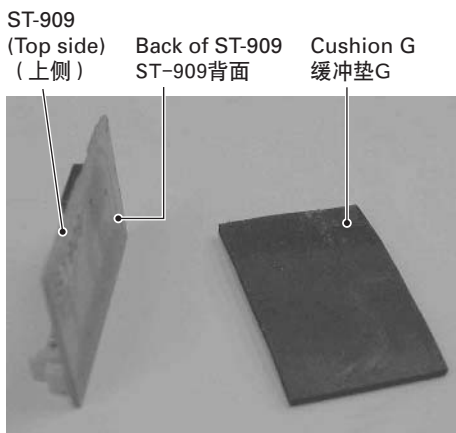

4. Connect the cable (E37-1117-05) to the topside of the ST-909.

4. 把电缆 (E37-1117-05) 连接到ST-909上部。

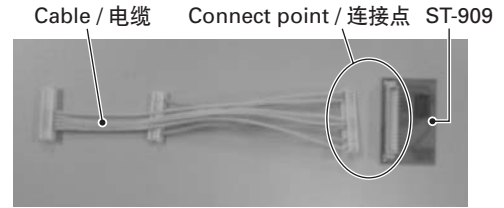

5. Mount the ST-909 onto the TX-RX PCB using the adhesive cushion on the underside of the ST-909, onto the left edge of the silk-screen area. Connect the cables to the two terminals.

5. 使用ST-909下侧的粘合剂缓冲垫把ST-909安装到TX-RX PCB板上丝网印刷电路区域的左边缘。然后把电缆线连接到2个终端接线座上。



6. Adhere the 13 x 9 x 8 mm cushion F (G13-2006-04) to the top side of the ST-865KW4, between the variable resistor (R18) and the capacitor (C19), then place the supplied insulation sheet over the integrated circuit (IC).

6. 把13 x 9 x 8mm缓冲垫F (G13-2006-04) 粘附到ST-865KW4的上部, 位于可变电阻器 (R18) 和电容器 (C19) 之间, 然后把提供的电气绝缘片装在集成电路 (IC) 上。

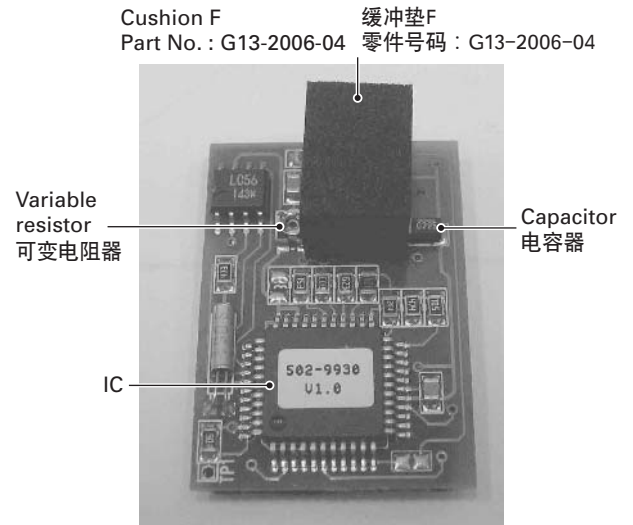

INSTALLATION / 安装

Insulation sheet / 绝缘片

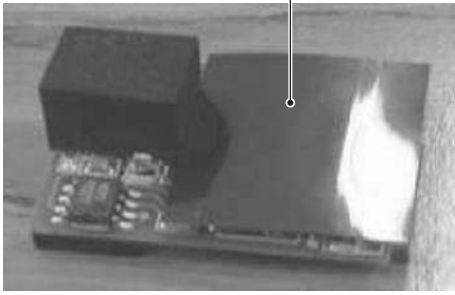

7. Adhere the 10 x 10 x 2.5 mm cushion E (G13-2007-04) and the supplied 20 x 20 x 1mm cushion C to the underside of the ST-865KW4 as shown in the diagram below.

7. 如下图所示,把10 × 10 × 2.5mm缓冲垫E (G13-2007-04) 和提供的20 × 20 × 1mm缓冲垫C装到ST-865KW4的下部。

Cushion E
Part No. : G13-2007-04
缓冲垫E
零件号码 : G13-2007-04

Cushion C
缓冲垫C

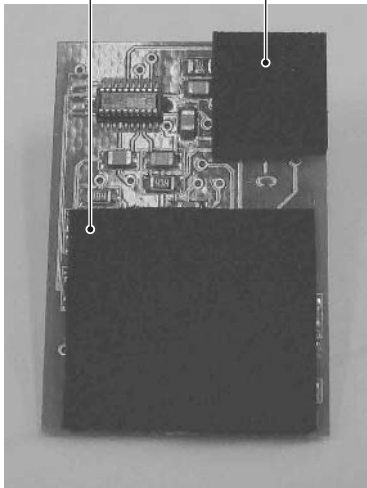

8. Align the connector on the underside of the ST-865KW4 with the connector on the top side of the ST-909, then press down on cushion E to secure them.

8. 连接ST-909上部的连接器和ST-865KW4下部的连接器,然后按缓冲垫E来紧固它们。



9. Flatten the cable so as to avoid potential damage when mounting the shielding cover. Mount the shielding cover and secure it with the five M2.6 screws.

9. 使电缆线平整以避免在安装屏蔽罩时可能的损坏。然后安装屏蔽罩并用5个M2.6螺丝拧紧固定。

Screw hole / 螺丝孔

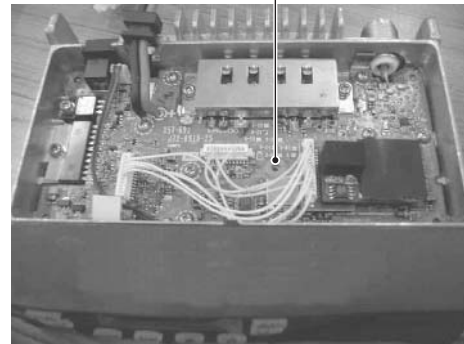

Note :

- For the SmarTrunk option, cushion C and the insulation sheet are included in the package.
- For TK-7108 & TK-8108 series, cushion A is not used. Cushion A is replaced by cushion F.
- Cushion B is replaced by cushion E.

注 :

- 对于SmarTrunk的选件,缓冲垫C以及绝缘片均包含在包装内。
- 对于TK-7108和TK-8108系列不使用缓冲垫A。缓冲垫A被缓冲垫F取代。
- 缓冲垫B被缓冲垫E取代。

Note :

- ST-909 and ST-865KW4 are available from SmarTrunk Systems, Inc.

■ Setting With the KPG-70D

Select "External Devices" from the "Edit" menu and set the "SmarTrunk".

注 :

- ST-909和ST-865KW4为SmarTrunk Systems, Inc.公司的产品。

■ 用KPG-70D进行设置

在“编辑”菜单上选择“外部设备”,然后启动“SmarTrunk”。

DISASSEMBLY FOR REPAIR / 维修时拆卸部件

1. When you remove the panel, turn the transceiver up side down. Detach the panel by lifting the tabs as shown below.

1. 要卸下面板时, 请翻转通信机, 按下图所示抬起翼片卸除面板。

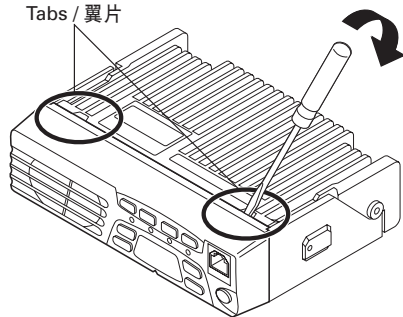

Fig. 1 / 图1

2. To remove the cabinet, first turn the transceiver up side down. Detach the cabinet by prying the tabs as shown below.

2. 要卸下机箱时, 请先翻转通信机, 按下图所示撬起翼片卸除机箱。

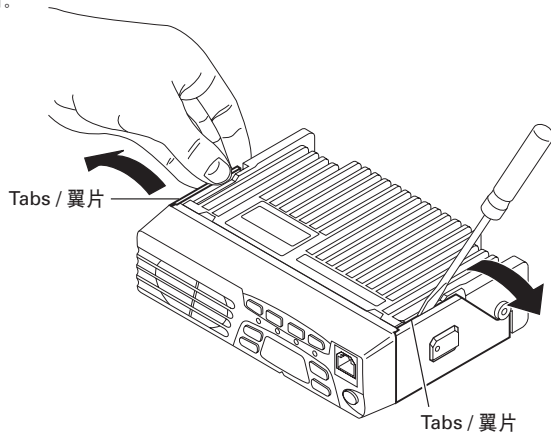

Fig. 2 / 图2

3. To remove the display unit PCB, detach the PCB by lifting at the indents of the PCB as shown below.

3. 要卸下显示单元电路板时, 请按下图所示抬起电路板的榫接部卸除电路板。

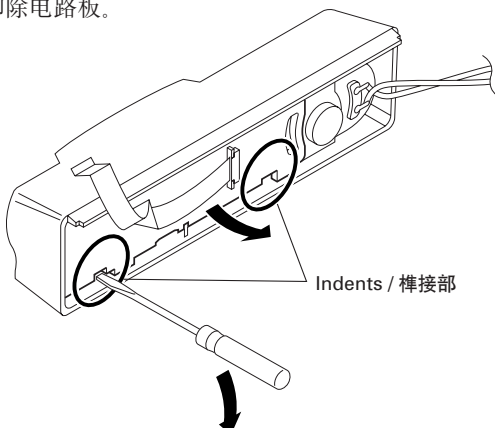

Fig. 3 / 图3

4. Mount the display unit

To mount the display unit on the panel, follow the correct procedures shown to ensure easy display unit assembly and good fitting onto the panel.

① Snap in bottom of display unit first.

② Snap in top of display unit.

4. 安装显示单元

如果在面板上安装显示单元, 必须按照正确的程序来操作, 以便确保安装容易和显示单元被良好地安装。

① 首先, 将显示单元的底部卡入。

② 然后将显示单元的顶部卡入。

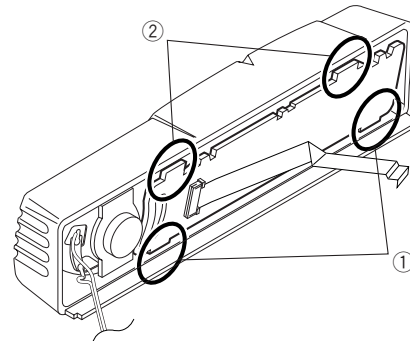

Fig. 4 / 图4

5. When mounting the front panel, match the 4 tabs of the chassis with the panel, being sure they attach securely.

5. 安装前面板时, 应将底架的4个翼片与面板接合, 并确保其结合紧密。

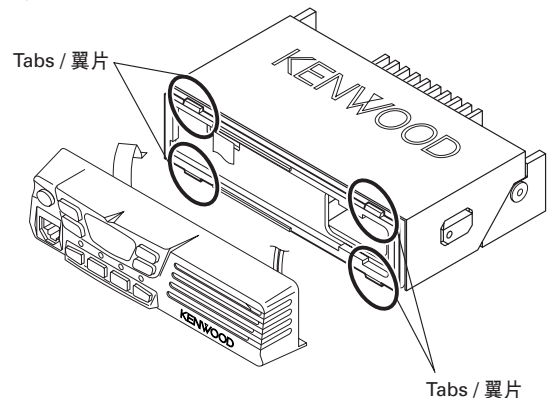

Fig. 5 / 图5

CIRCUIT DESCRIPTION / 电路说明

Frequency Configuration

The receiver utilizes double conversion. The first IF is 49.95MHz and the second IF is 450kHz. The first local oscillator signal is supplied from the PLL circuit.

The PLL circuit in the transmitter generates the necessary frequencies. Figure 1 shows the frequencies.

频率构成

接收部采用二次变频超外差方式。第一中频为49.95MHz，第二中频为450kHz。第一本振频率信号由锁相环电路提供。

发射部由锁相环电路直接产生所需要的频率。图1显示各种频率。

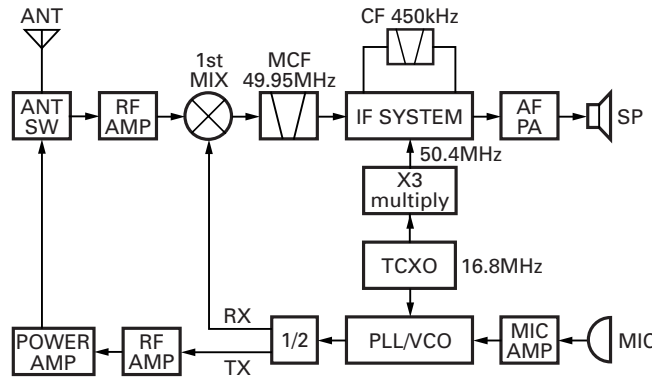

Fig. 1 Frequency configuration / 图1 频率构成

Receiver System

The receiver is double conversion superheterodyne. The frequency configuration is shown in Figure 1.

■ Front-end RF Amplifier

An incoming signal from the antenna is applied to an RF amplifier (Q353) after passing through a transmit/receive switch circuit (D603, D604 are off) and a band pass filter (L357, L356 and varactor diodes: D353, D354). After the signal is amplified (Q353), the signal is filtered through a band pass filter (L354, L355 and varactor diodes: D351, D352) to eliminate unwanted signals before it is passed to the first mixer.

The voltage of these diodes are controlled by tracking the CPU (IC101) center frequency of the band pass filter. (See Fig. 2)

■ First Mixer

The signal from the RF amplifier is heterodyned with the first local oscillator signal from the PLL frequency synthesizer circuit at the first mixer (Q352) to create a 49.95MHz first intermediate frequency (1st IF) signal. The first IF signal is then fed through one pair of monolithic crystal filter (MCF: XF351) to further remove spurious signals.

接收部系统

接收部为二次变频超外差方式。频率构成如图1所示。

■ 前级射频放大器

从天线进入的信号经过收发转换电路 (D603, D604断开) 和带通滤波器 (L357, L356和变容二极管: D353, D354) 进入射频放大器 (Q353)。信号被放大 (Q353) 之后, 信号被带通滤波 (L354, L355和变容二极管: D351, D352) 滤波, 在进入第一混频器之前消除不需要的信号。

通过跟踪带通滤波器的CPU (IC101) 中心频率来控制这些二极管的电压。(参见图2)

■ 第一混频器

来自于射频放大器的信号与来自于第一混频器 (Q352) 的锁相环频率合成电路的第一本振信号混合后产生49.95MHz的第一中频 (1st IF) 信号。然后, 第一中频信号进入两个单片晶体滤波器 (MCFs: XF351) 进一步消除寄生信号。

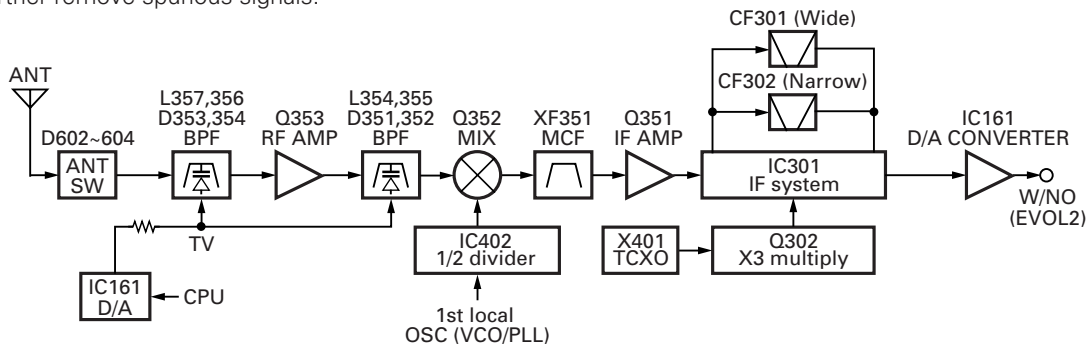

Fig. 2 Receiver system / 图2 接收部系统

CIRCUIT DESCRIPTION / 电路说明

■ IF Amplifier

The first IF signal is amplified by Q351, and the enters IC301 (FM processing IC). The signal is heterodyned again with a second local oscillator signal within IC301 to create a 450kHz second IF signal. The second IF signal is then fed through a 450kHz ceramic filter (Wide : CF301, Narrow : CF302) to further eliminate unwanted signals before it is amplified and FM detected in IC301.

Item	Rating
Nominal center frequency	49.95MHz
Pass bandwidth	$\pm 5.0\text{kHz}$ or more at 3dB
35dB stop bandwidth	$\pm 20.0\text{kHz}$ or less
Ripple	1.0dB or less
Insertion loss	5.0dB or less
Guaranteed attenuation	80dB or more at $f_0 \pm 1\text{MHz}$ Spurious : 40dB or more within $f_0 \pm 1\text{MHz}$
Terminal impedance	350 Ω / 5.5pF

Table 1 Crystal filter (L71-0591-05) : XF351

Item	Rating
Nominal center frequency	450kHz
6dB bandwidth	$\pm 6.0\text{kHz}$ or more
50dB bandwidth	$\pm 12.5\text{kHz}$ or less
Ripple	2.0dB or less
Insertion loss	6.0dB or less
Guaranteed attenuation	35.0dB or more within $f_0 \pm 100\text{kHz}$
Terminal impedance	2.0k Ω

Table 2 Ceramic filter (L72-0993-05) : CF301

Item	Rating
Nominal center frequency	450kHz
6dB bandwidth	$\pm 4.5\text{kHz}$ or more
50dB bandwidth	$\pm 10.0\text{kHz}$ or less
Ripple	2.0dB or less
Insertion loss	6.0dB or less
Guaranteed attenuation	60.0dB or more within $f_0 \pm 100\text{kHz}$
Terminal impedance	2.0k Ω

Table 3 Ceramic filter (L72-0999-05) : CF302

■中频放大器

第一中频信号通过Q351被放大, 然后进入IC301 (调频处理芯片)。信号再次与IC301中的第二本振信号混合后产生450kHz的第二中频信号。第二中频信号在被放大之前进入450kHz的陶瓷滤波器 (宽 : CF301, 窄 : CF302) 进一步消除不需要的信号并且在IC301中调频检测。

项目	额定值
额定中心频率	49.95MHz
通频带宽	在3dB时 $\pm 5.0\text{kHz}$ 或更大
35dB停止带宽	$\pm 20.0\text{kHz}$ 或更小
脉动	1.0dB或更低
插入损耗	5.0dB或更低
保证衰减	在 $f_0 \pm 1\text{MHz}$ 时80dB或更大 寄生信号 : 在 $f_0 \pm 1\text{MHz}$ 之内40dB或更大
端点阻抗	350 Ω /5.5pF

表1 晶体滤波器 (L71-0591-05) : XF350

项目	额定值
额定中心频率	450kHz
6dB带宽	$\pm 6.0\text{kHz}$ 或更大
50dB带宽	$\pm 12.5\text{kHz}$ 或更小
脉动	2.0dB或更低
插入损耗	6.0dB或更低
保证衰减	在 $f_0 \pm 100\text{kHz}$ 之内35.0dB或更大
端点阻抗	2.0k Ω

表2 陶瓷滤波器 (L72-0993-05) : CF301

项目	额定值
额定中心频率	450kHz
6dB带宽	$\pm 4.5\text{kHz}$ 或更大
50dB带宽	$\pm 10.0\text{kHz}$ 或更小
脉动	2.0dB或更低
插入损耗	6.0dB或更低
保证衰减	在 $f_0 \pm 100\text{kHz}$ 之内60.0dB或更大
端点阻抗	2.0k Ω

表3 陶瓷滤波器 (L72-0999-05) : CF302

CIRCUIT DESCRIPTION / 电路说明

■ Wide/Narrow Switching Circuit

The Wide port (pin 65) and Narrow port (pin 64) of the CPU is used to switch between ceramic filters. When the Wide port is high, the ceramic filter SW diodes (D303, D302) cause CF301 to turn on to receive a Wide signal.

When the Narrow port is high, the ceramic filter SW diodes (D303, D302) cause CF302 to turn on to receive a Narrow signal.

■ 宽 / 窄转换电路

CPU的宽端口(管脚65)和窄端口(管脚64)用于陶瓷滤波器之间的切换。当宽端口为高电平时,陶瓷滤波器SW二极管(D303, D302)使CF301导通来接收宽带信号。

当窄端口为高电平时,陶瓷滤波器SW二极管(D303, D302)使CF302导通来接收窄带信号。

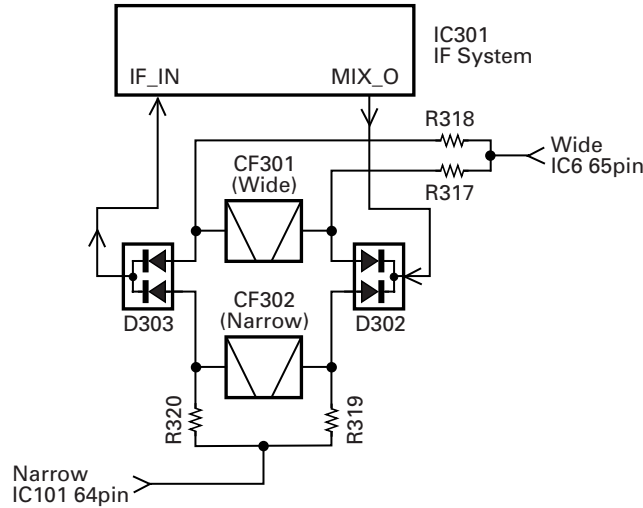

Fig. 3 Wide/Narrow switching circuit / 图3 宽 / 窄转换电路

■ AF Signal System

The detection signal from IF IC (IC301) goes to D/A converter (IC161) to adjust the gain and is output to AF filter (IC251) for characterizing the signal. The AF signal output from IC251 and the DTMF signal, BEEP signal are summed and the resulting signal goes to the D/A converter (IC161). The AFO output level is adjusted by the D/A converter. The signal output from the D/A converter is input to the audio power amplifier (IC252). The AF signal from IC252 switches between the internal speaker and speaker jack (J1) output.

■ 音频信号系统

来自于IF IC (IC301) 的检测信号进入数/模转换器 (IC161), 调整增益并输出到AF滤波器 (IC251) 来表示信号的特征。从IC161输出的AF信号, DTMF信号和BEEP信号被累加, 并且将获得的信号送到数/模转换器 (IC161)。AFO输出电平被数/模转换器调整。从数/模转换器输出的信号被输入到音频功率放大器 (IC252)。来自于IC252的AF信号在内部扬声器和扬声器插口 (J1) 输出之间变换。

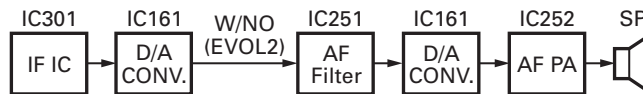

Fig. 4 AF signal system / 图4 音频信号系统

■ Squelch Circuit

The detection output from the FM IF IC (IC301) passes through a noise amplifier (Q301) to detect noise. A voltage is applied to the CPU (IC101). The CPU controls squelch according to the voltage (SQIN) level. The signal from the RSSI pin of IC301 is monitored. The electric field strength of the receive signal can be known before the SQIN voltage is input to the CPU, and the scan stop speed is improved.

■ 静噪电路

从调频中频芯片 (IC301) 输出的检测经过噪音放大器 (Q301) 检测噪音。向CPU (IC101) 输入电压。CPU按照电压 (SQIN) 电平控制静噪。来自于IC301的RSSI管脚的信号被监听。在SQIN电压被输入到CPU之前可以识别接收信号的电场强度, 并且扫描停止速度将增快。

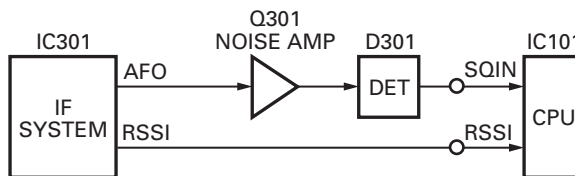

Fig. 5 Squelch circuit / 图5 静噪电路

CIRCUIT DESCRIPTION / 电路说明

PLL Frequency Synthesizer

The PLL circuit generates the first local oscillator signal for reception and the RF signal for transmission.

■ PLL

The frequency step of the PLL circuit is 5 or 6.25kHz. A 16.8MHz reference oscillator signal is divided at IC401 by a fixed counter to produce the 5 or 6.25kHz reference frequency. The voltage controlled oscillator (VCO) output signal is buffer amplified by Q410, then divided in IC401 by a dual-module programmable counter. The divided signal is compared in phase with the 5 or 6.25kHz reference signal in the phase comparator in IC401. The output signal from the phase comparator is filtered through a low-pass filter and passed to the VCO to control the oscillator frequency. (See Fig. 6)

■ VCO

The operating frequency is generated by Q406 in transmit mode and Q405 in receive mode. The oscillator frequency is controlled by applying the VCO control voltage, obtained from the phase comparator, to the varactor diodes (D405 and D406 in transmit mode and D403 and D404 in receive mode). The TX/RX pin is set low in receive mode causing Q408 and Q407 to turn Q406 off, and turn Q405 on. The TX/RX pin is set high in transmit mode. The outputs from Q405 and Q406 are amplified by Q410 and sent to the RF amplifiers.

■ Unlock Circuit

During reception, the 8RC signal goes high, the 8TC signal goes low, and Q34 turns on. Q33 turns on and a voltage is applied to the collector (8R). During transmission, the 8RC signal goes low, the 8TC signal goes high and Q36 turns on. Q35 turns on and a voltage is applied to 8T.

The CPU in the control unit monitors the PLL (IC401) LD signal directly. When the PLL is unlocked during transmission, the PLL LD signal goes low. The CPU detects this signal and makes the 8TC signal low. When the 8TC signal goes low, no voltage is applied to 8T, and no signal is transmitted.

锁相环频率合成器

锁相环电路产生接收机的第一本振信号和用于发射的射频载波信号。

■ 锁相环电路

锁相环电路的步进频率为5或6.25kHz。16.8MHz的参考振荡器信号通过一个混合计数器在芯片IC401中被分频生成5或6.25kHz参考频率。压控振荡器(VCO)输出信号通过Q410被缓冲放大,然后在芯片IC401中被双模可编程计数器分频。被分频的信号在带有5或6.25kHz参考信号的相位比较器的芯片IC401中被比较。从相位比较器输出的信号进入一个低通滤波器后,通过压控振荡器控制振荡频率。(参见图6)

■ 压控振荡器

在发射模式中通过Q406产生操作频率,在接收模式中通过Q405产生操作频率。控制信号通过相位比较器到变容二极管(在发射中为D405和D406,在接收模式中为D403和D404)。在接收模式中,由于Q408和Q407切断Q406并且导通Q405,所以发射/接收管脚设置为低电平。发射-接收管脚在发射模式内被设置为高电平。来自于Q405和Q406的输出被Q410放大并送至RF放大器。

■ 失锁电路

在接收的过程中,8RC信号为高电平,8TC信号为低电平,并且Q34导通。Q33导通并且向集合器(8R)提供电压。在发射过程中,8RC信号为低电平,8TC信号为高电平,并且Q36导通。Q35导通并且向8T提供电压。

控制单元中的CPU直接监听锁相环电路(IC401)LD信号。当发射过程中锁相环电路失锁时,锁相环电路LD信号为低电平。CPU检测此信号并使8TC信号变为低电平。当8TC信号为低电平时,不向8T提供电压,并且不发射任何信号。

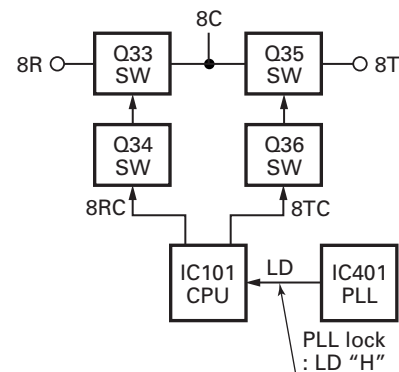

Fig. 7 Unlock circuit / 图7 失锁电路

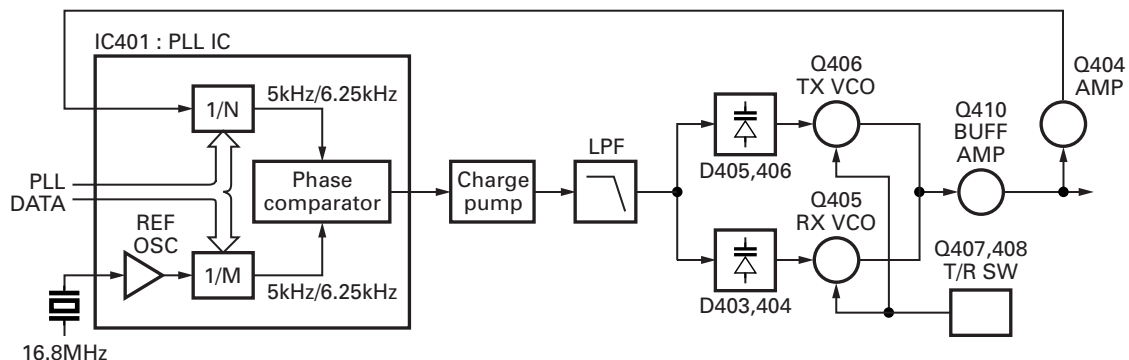

Fig. 6 PLL circuit / 图6 锁相环电路

CIRCUIT DESCRIPTION / 电路说明

Transmitter System

■ Outline

The transmitter circuit produces and amplifies the desired frequency directly. It FM-modulates the carrier signal by means of a varicap diode.

■ Power Amplifier Circuit

The transmit output signal from the VCO passes through the transmission/reception selection diode (D409) and amplified by Q501 and Q502. The amplified signal goes to the power amplifier (IC502) through a low-pass filter. The low-pass filter removes unwanted high-frequency harmonic components, and the resulting signal is goes the antenna terminal.

■ APC Circuit

The automatic transmission power control (APC) circuit detects the power amplifier (IC502) output with a diode (D606, D607) and applies a voltage to IC501. IC501 compares the APC control voltage (PC) generated by the D/A converter (IC161) and DC amplifier (IC203) with the detection output voltage. IC501 generates the voltage to control IC502 and stabilizes transmission output.

The APC circuit is configured to protect over current of IC502 due to fluctuations of the load at the antenna end and to stabilize transmission output at voltage and temperature variations.

发射部系统

■ 概要

发射部电路直接产生和放大需要的频率。通过各色二极管的含义对载波信号进行频率调制。

■ 功率放大器电路

来自于压控振荡器的发射信号经过发射/接收选择二极管 (D409) 并通过驱动装置 (Q501和Q502) 被放大为功率模组 (IC502) 的一个特定电平。被放大的信号进入一个低通滤波器。此低通滤波器消除不必要的高频谐波成份, 获得的信号进入天线终端。

■ 自动功率控制电路

自动发射功率控制 (APC) 电路使用一个二极管 (D606, D607) 检测功率模组 (IC502) 输出的一部分, 并向 IC501 提供电压。IC501 将 D/A 变换器 (IC161) 和 DC 放大器 (IC203) 产生的 APC 控制电压 (PC) 与检测输出电压进行比较。IC501 产生电压控制 IC502, 使发射输出稳定。

自动功率控制电路的构成用于防止由于天线终端负载的波动而产生的功率模组 (IC502) 的过载电流并且使发射输出电压和温度变化稳定。

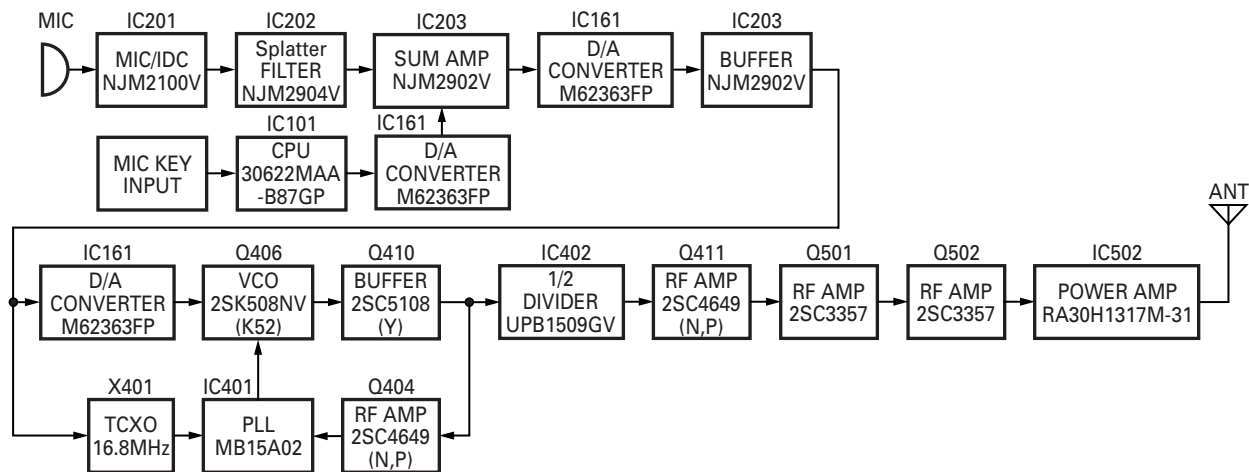

Fig. 8 Transmitter system / 图8 发射部系统

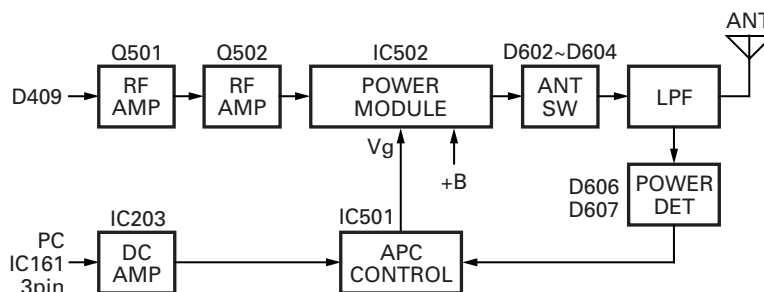

Fig. 9 APC circuit / 图9 自动功率控制电路

CIRCUIT DESCRIPTION / 电路说明

Control Circuit

The CPU carries out the following tasks:

- 1) Controls the WIDE, NARROW, TX/RX outputs.
- 2) Adjusts the AF signal level of the AF filter (IC251) and turns the filter select compounder on or off.
- 3) Controls the display unit.
- 4) Controls the PLL (IC401).
- 5) Controls the D/A converter (IC161) and adjusts the volume, modulation and transmission power.

Memory Circuit

The transceiver has a 64k-bit EEPROM (IC66). The EEPROM contains adjustment data. The CPU (IC101) controls the EEPROM through three serial data lines.

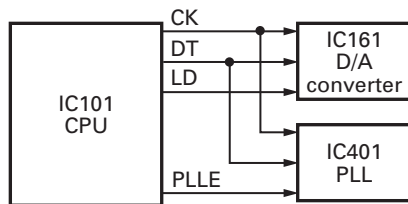

Fig. 10 Control circuit / 图10 控制电路

控制电路

CPU具有下述任务：

- 1) 控制宽, 窄, 发射 / 接收输出。
- 2) 调整AF滤波器 (IC251) 的AF信号电平并且开启或关闭滤波器选择混合器。
- 3) 控制显示单元。
- 4) 控制锁相环电路 (IC401)。
- 5) 控制数/模转换器 (IC161) 并且调整音量, 调制和发射功率。

存储器电路

车载台具有一个64k-bit EEPROM (IC66)。EEPROM包含调整数据。CPU (IC101) 经过三条串行数据线控制EEPROM。

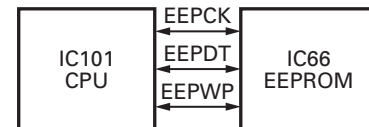

Fig. 11 Memory circuit / 图11 存储器电路

Display Circuit

The shift register controls the display LEDs through the CL and DI lines from the CPU (IC101).

When the transceiver is busy, LED G line becomes high impedance, turning on Q4 and the green LED (D11) lights, in transmit mode, the LED R line becomes low impedance, and the red LED (D12) lights.

Backlit LEDs (D1~D4) are provided and will only go on when MBL line becomes low impedance.

When a function key (MON, PF, C1, C2, C3 or C4) is selected, its respective line becomes low impedance (LED MON, LED PF, LED C1, LED C2, LED C3 or LED C4), the amber LED lights.

显示器电路

移位寄存器通过CPU (IC101) 输出过来的CL和DI信号来控制显示器LED。

当通信机接收时, LED G线变为高电平, 接通Q4使绿色LED (D11) 点亮, 在发射时LED R线变为低电平, 红色LED (D12) 点亮。

当MBL线变为低电平时, 背景照明LED (D1~D4) 被关闭。

当功能键 (MON, PF, C1, C2, C3或C4) 被按下后, 它们各自相应的线变成低电平 (LED MON, LED PF, LED C1, LED C2, LED C3或LED C4), 点亮橙色LED灯。

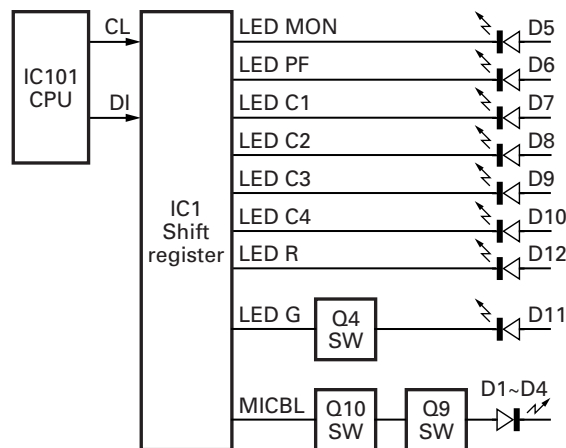

Fig. 12 Display circuit / 图12 显示电路

CIRCUIT DESCRIPTION / 电路说明

■ Key Matrix Circuit

The TK-7102 front panel has function keys. Each of them is connected to a cross point of a matrix of the KMI1 to KMO2 ports of the microprocessor. The KMO1 to KMO2 ports are always high, while the KMI1 to KMI4 ports are always low.

The microprocessor monitors the status of the KMI1 to KMO2 ports. If the state of one of the ports changes, the microprocessor assumes that the key at the matrix point corresponding to that port has been pressed.

■ 按键矩阵电路

TK-7108的前端面板有功能键。每一个按键被连接到微处理器的KMI1到KMO2端口矩阵的一个交叉点。当KMI1到KMI4端口通常为低电平时, KMO1到KMO2端口通常为高电平。

微处理器监听KMI1到KMO2端口的状态。如果其中一个端口的状态发生了变化, 微处理器认定对应于此端口的在矩阵点的按键已被按下。

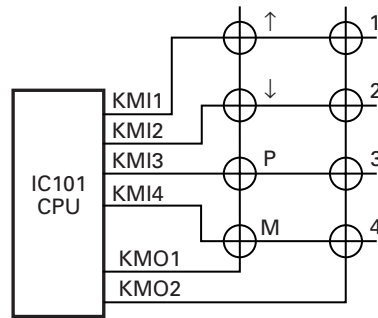

Fig. 13 Key matrix circuit / 图13 按键矩阵电路

■ Encode

The QT and DQT signals are output from QT/DQT of the CPU (IC101) and summed with the external pin DI line by the summing amplifier (IC203) and the resulting signal goes to the D/A converter (IC161). The DTMF signal is output from DTMF of the CPU and goes to the D/A converter (IC161). The signal is summed with a MIC signal by the summing amplifier (IC203), and the resulting signal goes to the D/A converter (IC161).

The D/A converter (IC161) adjusts the MO level and the balance between the MO and QT/DQT levels. Part of a QT/DQT signal is summed with MO and the resulting signal goes to the VCOMOD pin of the VCO. This signal is applied to a varicap diode in the VCO for direct FM modulation.

■ 编码

从CPU (IC101) 的QT/DQT输出的QT和DQT信号通过总和放大器 (IC203) 与外置引脚DI线计算总和。获得的信号进入数/模转换器 (IC161)。从CPU的DTMF输出的DTMF和信号进入数/模转换器 (IC161)。总和放大器 (IC203) 计算信号和MIC信号的总和, 获得的信号进入数/模转换器 (IC161)。

数/模转换器 (IC161) 调整MO电平和MO与QT/DQT电平之间的平衡。计算QT/DQT信号的端口和MO的总和, 获得的信号进入压控振荡器的VCOMOD管脚。此信号提供给压控振荡器中的各色二极管直接进行调频调制。

■ Decode

• QT/DQT/DTMF

The signal (W/NO (EVOL2)) goes to SIGNAL (pin 88) of CPU (IC101). The QT/DQT signal will pass through the low-pass filters in the CPU (IC101) and be decoded within the CPU (IC101). The DTMF signal will be decoded within the CPU (IC101).

■ 解码

• QT/DQT/DTMF

信号 (W/NO (EVOL2)) 进入到CPU (IC101) 的SIGNAL (引脚88)。QT/DQT信号将通过CPU (IC101) 上的低通滤波器, 并在CPU (IC101) 内被解码。DTMF信号也在CPU (IC101) 内被解码。

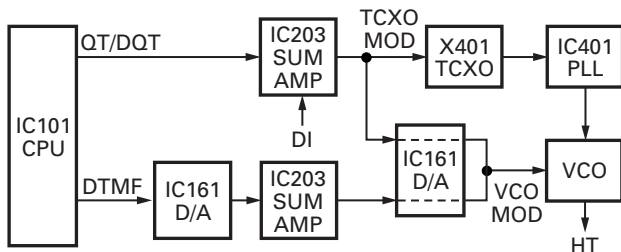

Fig. 14 Encode / 图14 编码



Fig. 15 Decode / 图15 解码

CIRCUIT DESCRIPTION / 电路说明

■ D/A Converter

The D/A converter (IC161) is used to adjust MO modulation, AF volume, TV voltage, FC reference voltage, and PC POWER CONTROL voltage level.

Adjustment values are sent from the CPU as serial data. The D/A converter has a resolution of 256 and the following relationship is valid:

$$\text{D/A output} = (\text{Vin} - \text{VDaref}) / 256 \times n + \text{VDaref}$$

Vin: Analog input

VDaref: D/A reference voltage

n: Serial data value from the microprocessor (CPU)

Power Supply Circuit

When the power switch on the display unit is pressed, the power port on the display unit which is connected port 17 (POWER), goes low, then port 82 (SBC) goes high, Q32 turns on, SB SW (Q31) turns on and power (SB) is supplied to the radio.

When the DC power supplied to the radio, the voltage regulator IC (IC33) supply into the CPU VDD and reset voltage detect IC (IC34). IC34 will generate signal (RESET) in to the reset terminal on the CPU (IC101) to carry out a power ON reset. Also, CPU (IC101) is checking on port 91 (Battery Voltage). If DC power is less than about 9.5V, the radio is unable to power on.

When the DC power voltage decreases from normal voltage, the INT voltage detector IC (IC35) will set to high on CPU port 18 (INT) if B line will became less than about 9.5V. Then CPU send to EEPROM (IC66) the backup data and go into STOP mode.

This circuit has an overvoltage protection circuit. If a DC voltage of 18V or higher is applied to the base of Q61, this voltage turns Q61 on and turns Q32 and SB off.

■数/模转换器

数/模转换器 (IC3) 用于调整MO调制, AF音量, TV电压, FC参考电压和PC POWER CONTROL电压电平。

从CPU以串行数据发送调整数值。数/模转换器的分辨率为256并且下述关系是有效的。

$$\text{数/模输出} = (\text{Vin} - \text{VDaref}) / 256 \times n + \text{VDaref}$$

Vin: 模拟输入

VDaref: 数/模参考电压

n: 来自于微处理器 (CPU) 的串行数据值

电源电路

当按下前面板中的POWER开关时, 显示板上与CPU端口17 (POWER) 相连接的电源端口为低电平, 然后CPU端口82 (SBC) 为高电平, Q32导通, SB SW (Q31) 导通并向通信机供电 (SB)。

此电路具有过载电压保护电路。如果18V或更高的电压被提供给电源电缆, 则D39导通并向Q38的基极提供电压。此电压使Q38导通, 使Q34和SB断开。

当DC电源提供到通信机时, 电压调整器IC (IC33) 供电给CPU VDD, 并且复位电压检测IC (IC34)。IC34将产生信号 (RESET) 传送到CPU (IC101) 的复位端子, 实行电源打开时的复位。另外, CPU (IC101) 检测端口91 (电池电压)。如果DC电源电压低于9.5V, 则通信机电源不能打开。

当DC电源电压从正常电压降低, INT电压检测IC (IC35) 将把CPU端口18 (INT) 置高。如果B线电压变为低于9.5V时, CPU会发送备份数据到EEPROM (IC66), 并且进入STOP模式。

此电路具有过电压保护电路。如果18V或更高的DC电压加到Q61的基极, 则此电压将接通Q61, 关闭Q32和SB。

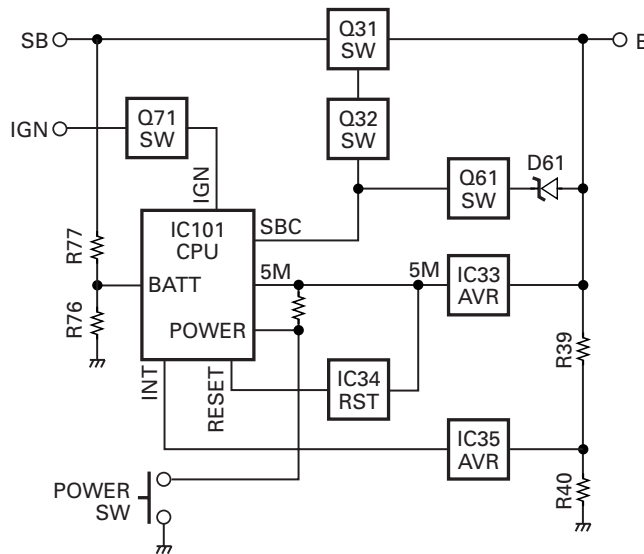

Fig. 16 Power supply circuit / 图16 电源电路

SEMICONDUCTOR DATA

Microprocessor : 30622MAA-B87GP (TX-RX Unit IC101)

■ Terminal Function

Pin No.	Name	I/O	Function
1	QT/DQT	O	QT/DQT output.
2	DTMF/MSK	O	DTMF/MSK/BEEP output
3	PLLE	O	PLL IC chip select.
4,5	NC	I	
6	GND	-	GND.
7	CNVSS	-	CNVss for flash.
8	EVLDD	O	E-volume LD.
9	BSHIFT	O	Beat shift.
10	RESET	-	Reset.
11	XOUT	-	X'tal (14.318MHz).
12	VSS	-	GND.
13	XIN	-	X'tal (14.318MHz).
14	VCC	-	+5V.
15	GND	-	GND (Input only).
16	NC	I	
17	POWER	I	Power key input.
18	INT	I	μcom stop.
19	NC	I	
20	TX/RX	O	TX/RX.
21	UL	O	PLL unlock detect.
22~25	NC	I	
26	EEPWP	O	EEPROM write protect
27	EEPCK	O	EEPROM clock (N ch open drain).
28	EEPDT	I/O	EEPROM data (N ch open drain).
29	FNC1	I/O	Function P1/TxD for flash.
30	FNC2	I/O	Function P2/RxD for flash.
31	CLKFLS	I	SCLK for flash.
32	BSYFLS	O	Busy for flash.
33	TXD	O	To FPU.
34	RXD	I	From FPU.
35	PTT	I	PTT key.
36	HOOK	I	Hook.
37,38	NC	I	
39	EMPFLS	I/O	EPM for flash.
40~42	NC	I	
43	FNC3	I/O	Function port 3.
44	CEFLS	I/O	CE for flash.
45,46	FNC4, FNC5	I/O	Function port 4, 5
47,48	FNC7, FNC6	I/O	Function port 7, 6.
49	FNC8	I/O	Function port 8.
50	AFM	O	AF mute.
51	SPM	O	Speaker mute.

Pin No.	Name	I/O	Function
52	AMPSW	O	AF AMP switch.
53	DT	O	Common data.
54	CK	O	Common clock.
55,56	NC	I	
57~59	DST1~DST3	I	Destination 1~3
60	VCC	-	+5V.
61	NC	I	
62	VSS	-	GND.
63	NC	I	
64	NARROW	O	
65	WIDE	O	
66~68	NC	I	
69	CL	O	Clock for LCD.
70	CE	O	Chip enable for LCD.
71	DI	O	Transfer data to LCD.
72	IGN	I	Ignition.
73	MICMT1	O	Mic 1 mute.
74	MICEM	O	Mic 2 mute.
75	MICMT2	O	Mic 3 mute.
76	8RC	O	8R control.
77	8TC	O	8T control.
78	CM	I/O	Mic key check.
79~81	NC	I	
82	SBC	O	Battery switch.
83	KMI2	I	Key matrix 2.
84	KMI1	I	Key matrix 1.
85	KMI3	I	Key matrix 3.
86	KMI4	I	Key matrix 4.
87	NC	I	
88	SIGNAL	I	DTMF/QT/DQT input.
89	TEMP2	I	Temperature 2.
90	TEMP1	I	Temperature 1.
91	BATT	I	Battery voltage.
92	RSSI	I	RSSI input.
93	SQIN	I	Squelch input.
94	AVSS	-	GND.
95	NC	I	
96	VREF	-	+5V.
97	AVCC	-	+5V.
98	NC	I	
99	KMO1	O	Key matrix output 1.
100	KMO2	O	Key matrix output 2.

半导体数据

微处理器：30622MAA-B87GP (TX-RX单元IC101)

■ 端子功能

管脚号	端口名称	输入/输出	功 能
1	QT/DQT	输出	QT/DQT输出
2	DTMF/MSK	输出	DTMF/MSK/BEEP输出
3	PLLE	输出	锁相环IC芯片选择
4, 5	NC	输入	
6	GND	-	接地
7	CNVSS	-	闪存用CNVss
8	EVLLD	输出	E-音量LD
9	BSHIFT	输出	时钟偏移
10	RESET	-	复位
11	XOUT	-	X' tal (14.318MHz)
12	VSS	-	接地
13	XIN	-	X' tal (14.318MHz)
14	VCC	-	+5V
15	GND	-	接地 (输入)
16	NC	输入	
17	POWER	输入	电源键输入
18	INT	输入	μCOM停止
19	NC	输入	
20	TX/RX	输出	发射/接收
21	UL	输出	锁相环解锁检测
22 ~ 25	NC	输入	
26	EEPWP	输出	EEPROM写保护
27	EEPCK	输出	EEPROM时钟
28	EEPDT	输入/输出	EEPROM数据
29	FNC1	输入/输出	闪存用功能P1/TxD
30	FNC2	输入/输出	闪存用功能P2/RxD
31	CLKFLS	输入	闪存用SCLK
32	BSYFLS	输出	闪存用Busy
33	TXD	输出	到FPU
34	RXD	输入	由FPU
35	PTT	输入	PTT键
36	HOOK	输入	挂钩
37, 38	NC	输入	
39	EMPFLS	输入/输出	闪存用EPM
40 ~ 42	NC	输入	
43	FNC3	输入/输出	功能端口3
44	CEFLS	输入/输出	闪存用CE
45, 46	FNC4, FNC5	输入/输出	功能端口4, 5
47, 48	FNC7, FNC6	输入/输出	功能端口7, 6
49	FNC8	输入/输出	功能端口8
50	AFM	输出	音频静音
51	SPM	输出	扬声器静音

管脚号	端口名称	输入/输出	功 能
52	AMPSW	输出	音频放大开关
53	DT	输出	公共数据
54	CK	输出	公共时钟
55, 56	NC	输入	
57~59	DST1 ~ DST3	输入	目的地1~3
60	VCC	-	+5V
61	NC	输入	
62	VSS	-	接地
63	NC	输入	
64	NARROW	输出	
65	WIDE	输出	
66 ~ 68	NC	输入	
69	CL	输出	LCD时钟
70	CE	输出	LCD芯片启动
71	DI	输出	传送数据到LCD
72	IGN	输入	点火
73	MICMT1	输出	话筒1静音
74	MICEM	输出	话筒2静音
75	MICMT2	输出	话筒3静音
76	8RC	输出	8R控制
77	8TC	输出	8T控制
78	CM	输入/输出	话筒键检查
79 ~ 81	NC	输入	
82	SBC	输出	电池开关
83	KMI2	输入	键矩阵输入2
84	KMI1	输入	键矩阵输入1
85	KMI3	输入	键矩阵输入3
86	KMI4	输入	键矩阵输入4
87	NC	输入	
88	SIGNAL	输入	DTMF/QT/DQT输入
89	TEMP2	输入	温度2
90	TEMP1	输入	温度1
91	BATT	输入	电池电压
92	RSSI	输入	RSSI输入
93	SQIN	输入	静噪输入
94	AVSS	-	接地
95	NC	输入	
96	VREF	-	+5V
97	AVCC	-	+5V
98	NC	输入	
99	KMO1	输出	键矩阵输出1
100	KMO2	输出	键矩阵输出2

COMPONENTS DESCRIPTION

Display Unit (X54-3460-20)

Ref. No.	Parts name	Description
IC1	IC	Shift register for LED & MICBL control
Q4	Transistor	Busy light switch
Q9,10	Transistor	Key backlit switch
D1~4	LED	Key backlit
D5	LED	Monitor key light
D6	LED	Programmable key light
D7~10	LED	Channel key light
D11	LED	Busy
D12	LED	Transmit
D13	Diode	Surge protection

TX-RX Unit (X57-6913-01)

Ref. No.	Parts name	Description
IC31	IC	Voltage regulator (8C)
IC32	IC	Voltage regulator (5C)
IC33	IC	Voltage regulator (5M)
IC34	IC	Voltage detector reset
IC35	IC	Voltage detector int
IC66	IC	EEPROM
IC101	IC	CPU
IC161	IC	Digital potentiometer
IC201	IC	MIC amplifier / IDC
IC202	IC	MIC amplifier / Splatter filter
IC203	IC	Buffer amplifier / SUM amplifier / DC amplifier / 1/2 Vcc
IC251	IC	Audio filter
IC252	IC	Audio amplifier
IC301	IC	FM demodulation
IC401	IC	PLL synthesizer
IC402	IC	Divider (Hetero)
IC501	IC	APC controller
IC502	IC	Power module
Q1	FET	TX AF
Q31	Transistor	DC switch (SB) / Active when power is on
Q32	FET	DC switch (SB) / Active when power is on
Q33,34	Transistor	DC switch (8R) / Active while RX
Q35,36	Transistor	DC switch (8T) / Active while TX
Q61	Transistor	Over voltage detection / Active when PS voltage is more than 18V
Q71	Transistor	Ignition / Ignition sens
Q86,87	Transistor	Beat shift / Active while beat shift is on
Q201	Transistor	AF amplifier / MIC mute / Emergency MIC mute
Q202	FET	Emergency MIC mute / Active when MICEM is H

Ref. No.	Parts name	Description
Q251	Transistor	Buffer amplifier / RX audio
Q252,253	FET	AF mute / Active while AFM is H
Q254	Digital transistor	AF mute / Active while SPM is H
Q255	Transistor	AF mute / Active while AMPSW is H
Q301	Transistor	Noise amplifier / SQL amplifier
Q302	Transistor	Buffer amplifier / 16.8MHz 3rd over tone
Q351	Transistor	IF amplifier
Q352	FET	Mixer
Q353	FET	RF amplifier / LNA
Q354	Transistor	PC/TV SW
Q402,403	Transistor	Charge pump
Q404	Transistor	RF amplifier / PLL F in
Q405	FET	RX VCO
Q406	FET	TX VCO
Q407	FET	T/R switch
Q408	Transistor	T/R switch
Q410	Transistor	Buffer amplifier / Output of VCO
Q411	Transistor	RF amplifier / Output of VCO
Q440	Transistor	Lipple filter
Q501,502	Transistor	RF amplifier
D1	Diode	Surge absorption / CM
D2	Diode	Surge absorption / HOOK
D3	Diode	Surge absorption / PTT
D4~11	Diode	Surge absorption / FNC1~8
D31	Diode	Reverse connection protection
D32	Poly switch	Current protection
D61	Diode	Over voltage detection
D201	Diode	OR gate / MIC mute, AGC
D202	Diode	AGC
D251	Diode	Limiter
D301	Diode	Detection
D302,303	Diode	IF switch (Wide/Narrow)
D351~354	Varicap	RF BPF tuning
D401	Diode	Lipple filter
D402	Diode	Voltage dropped
D403,404	Varicap	RX VCO
D405,406	Varicap	TX VCO
D407	Varicap	Modulation
D408	Diode	Lipple filter
D409	Diode	RF switch (TX/RX)
D501,502	Diode	Temperature compensation
D503	Diode	Voltage protection
D602,603	Diode	ANT switch
D606,607	Diode	APC voltage detect
D608,609	Diode	Temperature compensation

元件说明

显示单元 (X54-3460-20)

有关号码	零件名称	说明
IC1	IC	LED & MICBL控制用移位寄存器
Q4	晶体管	繁忙灯光开关
Q9, 10	晶体管	按键背景灯光开关
D1 ~ 4	发光二极管	按键背景灯光
D5	发光二极管	监听键灯光
D6	发光二极管	可编程键灯光
D7 ~ 10	发光二极管	信道键灯光
D11	发光二极管	繁忙
D12	发光二极管	发射
D13	二极管	过压保护

TX-RX单元 (X57-6913-01)

有关号码	零件名称	说明
IC31	IC	电压调节器 (8C)
IC32	IC	电压调节器 (5C)
IC33	IC	电压调节器 (5M)
IC34	IC	电压检测器复位
IC35	IC	电压检测器int
IC66	IC	EEPROM
IC101	IC	微处理器
IC161	IC	数码电位计
IC201	IC	扬声器放大/IDC
IC202	IC	扬声器放大/边带干扰消除器
IC203	IC	缓冲放大器/总和放大器/直流放大器/ 1/2Vcc
IC251	IC	音频过滤器
IC252	IC	音频放大器
IC301	IC	FM检波
IC401	IC	锁相环同步器
IC402	IC	分频器 (复合式)
IC501	IC	APC控制器
IC502	IC	功率模块
Q1	场效应管音	发射音频
Q31	晶体管	直流开关 (SB)/通电时生效
Q32	场效应管音	直流开关 (SB)/通电时生效
Q33, 34	晶体管	直流开关 (8R)/接收生效
Q35, 36	晶体管	直流开关 (8T)/发射生效
Q61	晶体管	过电压检测/PS电压大于18V时启动
Q71	晶体管	点火/点火器传感
Q86, 87	晶体管	拍频偏移/节拍漂移开启时启动
Q201	晶体管	音频放大器/话筒静音/紧急话筒静音
Q202	场效应管音	紧急话筒静音/当MICEM是H时生效
Q251	晶体管	缓冲放大器/接收音频

有关号码	零件名称	说明
Q252, 253	场效应管音	音频静音/当AFM是H时生效
Q254	数字晶体管	音频静音/当SPM是H时生效
Q255	晶体管	音频静音/当AMPSW是H时生效
Q301	晶体管	噪声放大器/SQL放大器
Q302	晶体管	缓冲放大器/16.8MHz第三完毕提示音
Q351	晶体管	中频放大器
Q352	场效应管音	混频器
Q353	场效应管音	射频放大器/LNA
Q354	晶体管	PC/TV开关
Q402, 403	晶体管	负载增压
Q404	晶体管	射频放大器/锁相环散热片
Q405	场效应管音	接收压空振荡器
Q406	场效应管音	发射压空振荡器
Q407	场效应管音	发射 / 接收开关
Q408	晶体管	发射 / 接收开关
Q410	晶体管	缓冲放大器/VCO输出
Q411	晶体管	射频放大器/VCO输出
Q440	晶体管	脉动滤波器
Q501, 502	晶体管	射频放大器
D1	二极管	过压吸收/CM
D2	二极管	过压吸收/HOOK
D3	二极管	过压吸收/PTT
D4 ~ 11	二极管	过压吸收/FNC1 ~ 8
D31	二极管	反向电流保护
D32	多相开关	电流保护
D61	二极管	过电压检测
D201	二极管	或门 / 话筒静音, AGC
D202	二极管	AGC
D251	二极管	限幅器
D301	二极管	检测
D302, 303	二极管	中频开关 (宽 / 窄)
D351 ~ 354	变容二极管	射频BPF调谐
D401	二极管	脉动滤波器
D402	二极管	电压降低
D403, 404	变容二极管	接收压空振荡器
D405, 406	变容二极管	接收压空振荡器
D407	变容二极管	调制
D408	二极管	脉动滤波器
D409	二极管	射频开关 (发射 / 接收)
D501, 502	二极管	温度补偿
D503	二极管	电压保护
D602, 603	二极管	天线开关
D606, 607	二极管	自动功率控制电压检测
D608, 609	二极管	温度补偿

TK-7108

PARTS LIST / 零件表

* New Parts. Δ indicates safety critical components.

Parts without **Parts No.** are not supplied.

Les articles non mentionnés dans le **Parts No.** ne sont pas fournis.

Teile ohne **Parts No.** werden nicht geliefert.

L : Scandinavia

K : USA

P : Canada

Y : PX (Far East, Hawaii)

T : England

E : Europe

Y : AAFES (Europe)

X : Australia

M : Other Areas

TK-7108, DISPLAY UNIT (X54-3460-20)

TX-RX UNIT (X57-6913-01)

Ref. No.	Address	New parts	Parts No.	Description	Destination
TK-7108					
1	1B		A01-2178-02	CABINET	
2	3B	*	A10-4080-01	CHASSIS	
3	3A		A62-0942-03	PANEL ASSY	
5	3A	*	B10-2753-03	FRONT GLASS	
7	1E	*	B62-1390-20	INSTRUCTION MANUAL	C
7	2C	*	B62-1664-10	INSTRUCTION MANUAL	M
8	3B	*	B72-1912-24	MODEL NAME PLATE	C
8	3B	*	B72-2100-14	MODEL NAME PLATE	M
10	3B		E04-0167-05	RF COAXIAL PECEPTACLE (M)	
12	1C		E30-3339-05	DC CORD ACCESSORY	M
13	2B		E30-3448-05	DC CORD (RADIO)	
14	3A		E37-0962-05	SPEAKER CABLE	
15	2A		E37-1041-05	FLAT CABLE (TX/RX-DISPLAY)	
20	2B		F10-2414-03	SHIELDING PLATE (POWER MODULE)	
21	2B	*	F10-2491-02	SHIELDING COVER (TX/RX)	
22	2B	*	F10-2498-03	SHIELDING CASE (POWER MODULE)	
23	1C		F51-0016-05	FUSE (6*30) ACCESSORY	M
25	2B		G02-0887-03	EARTH SPRING (ANTENNA TERMINAL)	
26	2B		G10-0792-14	FIBROUS SHEET (POWER MODULE)	
27	3A		G13-1836-04	CUSHION (SPEAKER)	
30	3B	*	G13-2003-04	CUSHION (DC CORD)	
34	1B		G53-1524-02	PACKING	
35	3B		G53-1525-03	PACKING	
36	2B		G53-1542-03	PACKING	
38	1C		H02-0617-02	INNER PACKING CASE	M
39	2D,1F		H10-6636-13	POLYSTYRENE FOAMED FIXTURE	
40	3C,2E		H10-6639-03	POLYSTYRENE FOAMED FIXTURE	
41	1C		H25-0103-04	PROTECTION BAG (125/250/0.07)	M
42	2D,1F		H25-2320-04	PROTECTION BAG	
43	3D		H52-1699-12	ITEM CARTON CASE	M
43	2F	*	H52-1700-12	ITEM CARTON CASE	C
46	1D		J29-0662-03	BRACKET ACCESSORY	M
48	2A		K29-9065-01	KEY TOP	
A	2B		N67-3008-46	PAN HEAD SEMS SCREW W	
B	2B,3B		N87-2606-46	BRAZIER HEAD TAPTITE SCREW	
C	1B,2B		N87-2614-46	BRAZIER HEAD TAPTITE SCREW	
50	1C		N99-0395-05	SCREW SET ACCESSORY	M
52	3A		T07-0739-05	SPEAKER	
DISPLAY UNIT (X54-3460-20)					
D1-4			B30-2238-05	LED (Y)	
D5-10			B30-2239-05	LED (SY)	
D11			B30-2237-05	LED (YG)	
D12			B30-2240-05	LED (SR)	
C4			CK73GB1H103K	CHIP C 0.010UF K	
C8-17			CK73GB1H103K	CHIP C 0.010UF K	
C18			CK73GB1A105K	CHIP C 1.0UF K	
C25			CK73GB1H103K	CHIP C 0.010UF K	
C27			CK73GB1C104K	CHIP C 0.10UF K	

Ref. No.	Address	New parts	Parts No.	Description	Destination
CN1			E40-6005-05	FLAT CABLE CONNECTOR	
J1			E08-0877-05	MODULAR JACK	
L1			L92-0138-05	FERRITE CHIP	
CP3,4			RK75GB1J392J	CHIP-COM 3.9K J 1/16W	
R1-6			RK73GB1J102J	CHIP R 1.0K J 1/16W	
R7-15			RK73FB2A272J	CHIP R 2.7K J 1/10W	
R16			RK73GB1J101J	CHIP R 100 J 1/16W	
R17			RK73GB1J100J	CHIP R 10 J 1/16W	
R18			RK73GB1J472J	CHIP R 4.7K J 1/16W	
R19,20			RK73GB1J222J	CHIP R 2.2K J 1/16W	
D13			DA221	DIODE	
IC1			BU2090FS	MOS IC	
Q4			KRC102S	DIGITAL TRANSISTOR	
Q9			KRA225S	DIGITAL TRANSISTOR	
Q10			KRC102S	DIGITAL TRANSISTOR	
TX-RX UNIT (X57-6913-01)					
C10			CK73GB1H102K	CHIP C 1000PF K	
C13-23			CK73GB1H471K	CHIP C 470PF K	
C26-28			CK73GB1H221K	CHIP C 220PF K	
C29			CK73GB1H471K	CHIP C 470PF K	
C30			CK73GB1H102K	CHIP C 1000PF K	
C33			CK73GB1H102K	CHIP C 1000PF K	
C34			C92-0721-05	ELECTRO 330UF 25WV	
C35-38			CK73GB1H102K	CHIP C 1000PF K	
C39,40			CK73GB1C104K	CHIP C 0.10UF K	
C41			C92-0795-05	CHIP-TAN 22UF 10WV	
C42			CK73GB1H103K	CHIP C 0.010UF K	
C43-45			C92-0795-05	CHIP-TAN 22UF 10WV	
C48			CK73GB1A105K	CHIP C 1.0UF K	
C49,50			CK73GB1H103K	CHIP C 0.010UF K	
C51			C92-0560-05	CHIP-TAN 10UF 6.3WV	
C52,53			CK73GB1H102K	CHIP C 1000PF K	
C54,55			CK73GB1C104K	CHIP C 0.10UF K	
C56			CK73GB1H102K	CHIP C 1000PF K	
C61			CK73GB1H102K	CHIP C 1000PF K	
C66			CK73GB1H102K	CHIP C 1000PF K	
C72			CK73GB1H102K	CHIP C 1000PF K	
C77,78			CK73GB1H102K	CHIP C 1000PF K	
C82			CK73GB1H102K	CHIP C 1000PF K	
C83			CK73GB1C104K	CHIP C 0.10UF K	
C87			CC73GCH1H180J	CHIP C 18PF J	
C88,89			CC73GCH1H060B	CHIP C 6.0PF B	
C90			CC73GCH1H180J	CHIP C 18PF J	
C97,98			CK73GB1H102K	CHIP C 1000PF K	
C101			CK73GB1H102K	CHIP C 1000PF K	
C102			CK73GB1C104K	CHIP C 0.10UF K	
C103			CK73GB1H102K	CHIP C 1000PF K	
C104			CK73GB1C104K	CHIP C 0.10UF K	
C151			CK73GB1H182K	CHIP C 1800PF K	
C152			CK73GB1H392K	CHIP C 3900PF K	
C161			CK73GB1H102K	CHIP C 1000PF K	

PARTS LIST / 零件表

TX-RX UNIT (X57-6913-01)

Ref. No.	Address	New parts	Parts No.	Description	Destination	Ref. No.	Address	New parts	Parts No.	Description	Destination
C162			C92-0507-05	CHIP-TAN 4.7UF 6.3WV		C307			CK73GB1E223K	CHIP C 0.022UF K	
C163			CK73GB1H102K	CHIP C 1000PF K		C308			CK73GB1H102K	CHIP C 1000PF K	
C164			C92-0560-05	CHIP-TAN 10UF 6.3WV		C309			CK73GB1E223K	CHIP C 0.022UF K	
C201			CK73GB1C104K	CHIP C 0.10UF K		C310			CK73FB1C334K	CHIP C 0.33UF K	
C202			CK73GB1H102K	CHIP C 1000PF K		C311,312			CK73GB1C104K	CHIP C 0.10UF K	
C203			CK73GB1C273K	CHIP C 0.027UF K		C313			C92-0662-05	CHIP-TAN 15UF 6.3WV	
C204			C92-0514-05	CHIP-TAN 2.2UF 10WV		C314			CK73GB1H103K	CHIP C 0.010UF K	
C205			CK73GB1C104K	CHIP C 0.10UF K		C315-318			CK73GB1C104K	CHIP C 0.10UF K	
C206			CK73GB1H102K	CHIP C 1000PF K		C319			CC73GCH1H101J	CHIP C 100PF J	
C207			CK73GB1C223K	CHIP C 0.022UF K		C322			CC73GCH1H560J	CHIP C 56PF J	
C208			CK73GB1H103K	CHIP C 0.010UF K		C323			CC73GCH1H271J	CHIP C 270PF J	
C210			CK73GB1C104K	CHIP C 0.10UF K		C324			CK73GB1H103K	CHIP C 0.010UF K	
C211			CK73GB1H821K	CHIP C 820PF K		C326			CK73GB1H103K	CHIP C 0.010UF K	
C212			CK73GB1H122K	CHIP C 1200PF K		C350			CK73GB1H471K	CHIP C 470PF K	
C213			CK73GB1H332K	CHIP C 3300PF K		C351			CC73GCH1H330J	CHIP C 33PF J	
C214			CC73GCH1H151J	CHIP C 150PF J		C353			CK73GB1H103K	CHIP C 0.010UF K	
C215			CK73GB1C104K	CHIP C 0.10UF K		C355			CC73GCH1H150J	CHIP C 15PF J	
C217,218			C92-0560-05	CHIP-TAN 10UF 6.3WV		C357			CK73GB1H103K	CHIP C 0.010UF K	
C220			C92-0507-05	CHIP-TAN 4.7UF 6.3WV		C358			CK73GB1H102K	CHIP C 1000PF K	
C221			CK73GB1C104K	CHIP C 0.10UF K		C359			CC73GCH1H080B	CHIP C 8.0PF B	
C225			C92-0004-05	CHIP-TAN 1.0UF 16WV		C360-362			CK73GB1H102K	CHIP C 1000PF K	
C226			CK73GB1H472K	CHIP C 4700PF K		C363			CK73GB1H103K	CHIP C 0.010UF K	
C227			CK73GB1E103K	CHIP C 0.010UF K		C364			CK73GB1H102K	CHIP C 1000PF K	
C228			C92-0560-05	CHIP-TAN 10UF 6.3WV		C366			CK73GB1C104K	CHIP C 0.10UF K	
C229			C92-0507-05	CHIP-TAN 4.7UF 6.3WV		C367			CC73GCH1H101J	CHIP C 100PF J	
C230			CK73GB1C104K	CHIP C 0.10UF K		C368			CC73GCH1H220J	CHIP C 22PF J	
C231,232			CK73GB1H102K	CHIP C 1000PF K		C369			CC73GCH1H040B	CHIP C 4.0PF B	
C233			C92-0507-05	CHIP-TAN 4.7UF 6.3WV		C370			CK73GB1H102K	CHIP C 1000PF K	
C250			CK73GB1C104K	CHIP C 0.10UF K		C371			CC73GCH1H020B	CHIP C 2.0PF B	
C251			C92-0714-05	CHIP-TAN 4.7UF 6.3WV		C372			CK73GB1H102K	CHIP C 1000PF K	
C252			CC73GCH1H390J	CHIP C 39PF J		C373			CC73GCH1H040B	CHIP C 4.0PF B	
C253,254			CK73GB1A105K	CHIP C 1.0UF K		C374			CC73GCH1H220J	CHIP C 22PF J	
C255			CK73GB1H822K	CHIP C 8200PF K		C375-380			CK73GB1H102K	CHIP C 1000PF K	
C256			CK73GB1E183K	CHIP C 0.018UF K		C382			CC73GCH1H220J	CHIP C 22PF J	
C257			CK73GB1C393K	CHIP C 0.039UF K		C383			CK73GB1H102K	CHIP C 1000PF K	
C258-261			CK73GB1H103J	CHIP C 0.010UF J		C384			CC73GCH1H010B	CHIP C 1.0PF B	
C262			CK73GB1H102K	CHIP C 1000PF K		C386			CC73GCH1H240J	CHIP C 24PF J	
C263,264			CK73GB1C333K	CHIP C 0.033UF K		C387			CK73GB1H102K	CHIP C 1000PF K	
C265,266			CK73GB1C104K	CHIP C 0.10UF K		C388			CC73GCH1H040B	CHIP C 4.0PF B	
C267			CK73GB1A474K	CHIP C 0.47UF K		C389			CK73GB1H102K	CHIP C 1000PF K	
C268			CK73GB1C104K	CHIP C 0.10UF K		C401-403			CC73GCH1H101J	CHIP C 100PF J	
C269			CK73GB1A105K	CHIP C 1.0UF K		C404			C92-0662-05	CHIP-TAN 15UF 6.3WV	
C270			C92-0507-05	CHIP-TAN 4.7UF 6.3WV		C406			CK73GB1H102K	CHIP C 1000PF K	
C271			CK73GB1H332K	CHIP C 3300PF K		C408			CC73GCH1H220J	CHIP C 22PF J	
C272			CK73GB1H102K	CHIP C 1000PF K		C409			CK73GB1C104K	CHIP C 0.10UF K	
C273			CK73GB1A105K	CHIP C 1.0UF K		C410			C92-0560-05	CHIP-TAN 10UF 6.3WV	
C274			CK73FB1C224K	CHIP C 0.22UF K		C411			CK73GB1C104K	CHIP C 0.10UF K	
C275			CK73GB1A105K	CHIP C 1.0UF K		C412			C92-0560-05	CHIP-TAN 10UF 6.3WV	
C276,277			CK73GB1H102K	CHIP C 1000PF K		C413			CK73GB1H103K	CHIP C 0.010UF K	
C278			CK73GB1C104K	CHIP C 0.10UF K		C414			CK73GB1C104K	CHIP C 0.10UF K	
C279			C92-0516-05	CHIP-TAN 4.7UF 16WV		C416-418			CK73GB1H102K	CHIP C 1000PF K	
C280			C92-0040-05	CHIP-ELE 47UF 16WV		C421,422			CK73GB1H471K	CHIP C 470PF K	
C281			CK73GB1H102K	CHIP C 1000PF K		C423			C92-0555-05	CHIP-TAN 0.047UF 35WV	
C282			C92-0722-05	ELECTRO 470UF 16WV		C424			C92-0004-05	CHIP-TAN 1.0UF 16WV	
C283			CK73GB1H102K	CHIP C 1000PF K		C425			C92-0001-05	CHIP C 0.1UF 35WV	
C301			C92-0507-05	CHIP-TAN 4.7UF 6.3WV		C426			CC73GCH1H270J	CHIP C 27PF J	
C302			CK73GB1H102K	CHIP C 1000PF K		C427			CC73GCH1H080B	CHIP C 8.0PF B	
C303			CK73GB1H472K	CHIP C 4700PF K		C428			CK73GB1H471K	CHIP C 470PF K	
C304,305			CC73GCH1H331J	CHIP C 330PF J		C429			CC73GCH1H010B	CHIP C 1.0PF B	
C306			CK73GB1H102K	CHIP C 1000PF K		C430,431			CC73GCH1H050B	CHIP C 5.0PF B	

PARTS LIST / 零件表

TX-RX UNIT (X57-6913-01)

Ref. No.	Address	New parts	Parts No.	Description	Destination	Ref. No.	Address	New parts	Parts No.	Description	Destination
C432			CC73GCH1H0R5B	CHIP C 0.5PF B		C612			C93-0557-05	CHIP C 7.0PF D	
C434			CK73GB1H471K	CHIP C 470PF K		C615			C93-0562-05	CHIP C 15PF J	
C435			CC73GCH1H100C	CHIP C 10PF C		C616,617			CK73GB1H102K	CHIP C 1000PF K	
C436			CC73GCH1H0R5B	CHIP C 0.5PF B		TC351			C05-0399-05	CERAMIC TRIMMER CAP (6PF)	
C437			CK73GB1H471K	CHIP C 470PF K		TC352			C05-0245-05	CERAMIC TRIMMER CAP (10PF)	
C438			CC73GCH1H020B	CHIP C 2.0PF B		TC401,402			C05-0245-05	CERAMIC TRIMMER CAP (10PF)	
C439			CC73GCH1H060B	CHIP C 6.0PF B		J1			E11-0425-05	3.5D PHONE JACK (3P)	
C440			CC73GCH1H070B	CHIP C 7.0PF B		CN1			E40-6268-05	FLAT CABLE CONNECTOR	
C441			CC73GCH1H0R5B	CHIP C 0.5PF B		CN2			E40-5702-05	PIN ASSY	
C442			C92-0560-05	CHIP-TAN 10UF 6.3WV		CN3			E40-6292-05	PIN ASSY	
C444			CK73GB1H471K	CHIP C 470PF K		CN5			E40-3246-05	PIN ASSY	
C448,449			CK73GB1H471K	CHIP C 470PF K		CN301-304			E23-1081-05	TERMINAL	
C450			C92-0568-05	CHIP-TAN 22UF 10WV		CN501-503			E23-1081-05	TERMINAL	
C451,452			CK73GB1H471K	CHIP C 470PF K		CF301			L72-0993-05	CERAMIC FILTER	
C453			CK73GB1H221K	CHIP C 220PF K		CF302			L72-0999-05	CERAMIC FILTER	
C454			CC73GCH1H060B	CHIP C 6.0PF B		L101			L92-0443-05	FERRITE CHIP	
C455			CC73GCH1H030B	CHIP C 3.0PF B		L201			L92-0443-05	FERRITE CHIP	
C456			CC73GCH1H020B	CHIP C 2.0PF B		L301			L34-4554-05	COIL	
C457			CK73GB1H102K	CHIP C 1000PF K		L302			L41-3385-08	SMALL FIXED INDUCTOR	
C458			CK73GB1H221K	CHIP C 220PF K		L303,304			L40-3381-86	SMALL FIXED INDUCTOR (0.33UH)	
C459			CK73GB1H102K	CHIP C 1000PF K		L351			L41-8285-08	SMALL FIXED INDUCTOR	
C460			CC73GCH1H180J	CHIP C 18PF J		L352			L41-5685-08	SMALL FIXED INDUCTOR	
C461			CK73GB1H102K	CHIP C 1000PF K		L354-356			L34-4612-05	AIR-CORE COIL	
C462			CC73GCH1H100C	CHIP C 10PF C		L357			L34-4611-05	AIR-CORE COIL	
C463,464			CK73GB1H102K	CHIP C 1000PF K		L401			L92-0443-05	FERRITE CHIP	
C465			CC73GCH1H220J	CHIP C 22PF J		L403			L41-1005-08	SMALL FIXED INDUCTOR	
C466			CC73GCH1H101J	CHIP C 100PF J		L404			L92-0442-05	FERRITE CHIP	
C467			CK73GB1H102K	CHIP C 1000PF K		L405			L92-0443-05	FERRITE CHIP	
C468			CK73GB1H221K	CHIP C 220PF K		L406,407			L40-2702-86	SMALL FIXED INDUCTOR (27UH)	
C471			CC73GCH1H100C	CHIP C 10PF C		L408			L40-2778-67	SMALL FIXED INDUCTOR (27NH)	
C501,502			CK73GB1H102K	CHIP C 1000PF K		L409-412			L40-2702-86	SMALL FIXED INDUCTOR (27UH)	
C503			CC73GCH1H101J	CHIP C 100PF J		L413			L40-3978-67	SMALL FIXED INDUCTOR (39NH)	
C504-507			CK73GB1H102K	CHIP C 1000PF K		L414,415			L40-4791-86	SMALL FIXED INDUCTOR (4.7UH)	
C509			CC73GCH1H150J	CHIP C 15PF J		L416,417			L92-0443-05	FERRITE CHIP	
C510			CC73GCH1H080B	CHIP C 8.0PF B		L418			L41-3375-06	SMALL FIXED INDUCTOR	
C511-514			CK73GB1H102K	CHIP C 1000PF K		L419			L41-1085-06	SMALL FIXED INDUCTOR	
C515			CC73GCH1H270J	CHIP C 27PF J		L420			L41-1585-06	SMALL FIXED INDUCTOR	
C516			C93-0557-05	CHIP C 7.0PF D		L421			L41-1085-06	SMALL FIXED INDUCTOR	
C517			C93-0559-05	CHIP C 9.0PF D		L422			L41-5675-06	SMALL FIXED INDUCTOR	
C518			C93-0558-05	CHIP C 8.0PF D		L501,502			L41-6875-08	SMALL FIXED INDUCTOR	
C522			CK73FB1H102K	CHIP C 1000PF K		L503			L34-4669-05	AIR-CORE COIL	
C524			C92-0004-05	CHIP-TAN 1.0UF 16WV		L509			L34-4667-05	AIR-CORE COIL	
C525			CK73GB1H102K	CHIP C 1000PF K		L601			L34-4668-05	AIR-CORE COIL	
C545			CK73GB1H102K	CHIP C 1000PF K		L603,604			L34-4670-05	AIR-CORE COIL	
C546			CK73GB1H221K	CHIP C 220PF K		L605			L34-4667-05	AIR-CORE COIL	
C556			CK73GB1H102K	CHIP C 1000PF K		X86			L77-1934-05	CRYSTAL RESONATOR (14.31818MH)	
C557,558			CK73GB1H103K	CHIP C 0.010UF K		X401			L77-1868-15	TCXO (16.8MHZ)	
C559			CK73GB1C104K	CHIP C 0.10UF K		XF351			L71-0591-05	MCF (49.95MHZ)	
C560			CK73GB1H102K	CHIP C 1000PF K		R1			RK73GB1J101J	CHIP R 100 J 1/16W	
C574			CK73GB1C104K	CHIP C 0.10UF K		R2			R92-1252-05	CHIP R 0 OHM J 1/16W	
C576			C92-0719-05	ELECTRO 47UF 25WV		R3			RK73GB1J102J	CHIP R 1.0K J 1/16W	
C601			CC73GCH1H120J	CHIP C 12PF J		R4			RK73GB1J332J	CHIP R 3.3K J 1/16W	
C603			C93-0603-05	CHIP C 1000PF K		R5			RK73GB1J223J	CHIP R 22K J 1/16W	
C604			C93-0554-05	CHIP C 4.0PF C		R31			RK73GB1J472J	CHIP R 4.7K J 1/16W	
C605			C93-0564-05	CHIP C 22PF J		R32			R92-1201-05	CHIP R 220 J 1/2W	
C606			CC73GCH1H0R5B	CHIP C 0.5PF B		R33			RK73GB1J473J	CHIP R 47K J 1/16W	
C607			CC73GCH1H020B	CHIP C 2.0PF B		R34			RK73GB1J472J	CHIP R 4.7K J 1/16W	
C608			C93-0565-05	CHIP C 27PF J		R35			RK73GB1J473J	CHIP R 47K J 1/16W	
C610			CC73GCH1H0R5B	CHIP C 0.5PF B							
C611			CC73GCH1H020B	CHIP C 2.0PF B							

PARTS LIST / 零件表

TX-RX UNIT (X57-6913-01)

Ref. No.	Address	New parts	Parts No.	Description	Destination	Ref. No.	Address	New parts	Parts No.	Description	Destination
R36			RK73GB1J152J	CHIP R 1.5K J 1/16W		R218			RK73GB1J823J	CHIP R 82K J 1/16W	
R37			R92-1252-05	CHIP R 0 OHM J 1/16W		R219			RK73GB1J184J	CHIP R 180K J 1/16W	
R38			RK73GB1J334J	CHIP R 330K J 1/16W		R220,221			RK73GH1J153D	CHIP R 15K D 1/16W	
R39			RK73GB1J474J	CHIP R 470K J 1/16W		R222			RK73GB1J102J	CHIP R 1.0K J 1/16W	
R40			RK73GB1J394J	CHIP R 390K J 1/16W		R223			RK73GB1J472J	CHIP R 4.7K J 1/16W	
R41			RK73GB1J334J	CHIP R 330K J 1/16W		R224			RK73GB1J102J	CHIP R 1.0K J 1/16W	
R61			RK73GB1J471J	CHIP R 470 J 1/16W		R225			RK73GB1J154J	CHIP R 150K J 1/16W	
R62			RK73GB1J102J	CHIP R 1.0K J 1/16W		R226			RK73GB1J104J	CHIP R 100K J 1/16W	
R66,67			RK73GB1J473J	CHIP R 47K J 1/16W		R227			RK73GB1J223J	CHIP R 22K J 1/16W	
R68,69			RK73GB1J102J	CHIP R 1.0K J 1/16W		R228			RK73GB1J103J	CHIP R 10K J 1/16W	
R70			RK73GB1J473J	CHIP R 47K J 1/16W		R229			RK73GB1J684J	CHIP R 680K J 1/16W	
R71			RK73GB1J472J	CHIP R 4.7K J 1/16W		R230			RK73GB1J124J	CHIP R 120K J 1/16W	
R72			RK73GB1J105J	CHIP R 1.0M J 1/16W		R231			RK73GB1J683J	CHIP R 68K J 1/16W	
R73			RK73GB1J104J	CHIP R 100K J 1/16W		R232			RK73GB1J912J	CHIP R 9.1K J 1/16W	
R74			RK73GB1J473J	CHIP R 47K J 1/16W		R233			RK73GB1J682J	CHIP R 6.8K J 1/16W	
R75			RK73GB1J102J	CHIP R 1.0K J 1/16W		R249-251			RK73GB1J473J	CHIP R 47K J 1/16W	
R76			RK73GH1J183D	CHIP R 18K D 1/16W		R252			RK73GB1J474J	CHIP R 470K J 1/16W	
R77		*	RK73GH1J134D	CHIP R 130K D 1/16W		R253			R92-1252-05	CHIP R 0 OHM J 1/16W	
R78			RK73GB1J102J	CHIP R 1.0K J 1/16W		R254			RK73GB1J681J	CHIP R 680 J 1/16W	
R81			RK73GB1J473J	CHIP R 47K J 1/16W		R255,256			RK73GB1J562J	CHIP R 5.6K J 1/16W	
R82			R92-1252-05	CHIP R 0 OHM J 1/16W		R257			RK73GB1J105J	CHIP R 1.0M J 1/16W	
R86			R92-1252-05	CHIP R 0 OHM J 1/16W		R258			RK73GB1J272J	CHIP R 2.7K J 1/16W	
R87			RK73GB1J102J	CHIP R 1.0K J 1/16W		R259			RK73GB1J123J	CHIP R 12K J 1/16W	
R91,92			RK73GB1J102J	CHIP R 1.0K J 1/16W		R260			RK73GB1J224J	CHIP R 220K J 1/16W	
R93			RK73GB1J822J	CHIP R 8.2K J 1/16W		R261			RK73GB1J124J	CHIP R 120K J 1/16W	
R94			RK73GB1J123J	CHIP R 12K J 1/16W		R262			RK73GB1J183J	CHIP R 18K J 1/16W	
R101,102			RK73GB1J473J	CHIP R 47K J 1/16W		R263			RK73GH1J913D	CHIP R 91K D 1/16W	
R103-106			RK73GB1J102J	CHIP R 1.0K J 1/16W		R264			RK73GH1J124D	CHIP R 120K D 1/16W	
R107,108			RK73GB1J473J	CHIP R 47K J 1/16W		R265			RK73GH1J562D	CHIP R 5.6K D 1/16W	
R109			RK73GB1J152J	CHIP R 1.5K J 1/16W		R266			RK73GB1J562J	CHIP R 5.6K J 1/16W	
R110			RK73GB1J473J	CHIP R 47K J 1/16W		R267			R92-0670-05	CHIP R 0 OHM	
R111			RK73GB1J102J	CHIP R 1.0K J 1/16W		R268			RK73GB1J102J	CHIP R 1.0K J 1/16W	
R112,113			RK73GB1J473J	CHIP R 47K J 1/16W		R269			RK73GB1J823J	CHIP R 82K J 1/16W	
R114-119			RK73GB1J102J	CHIP R 1.0K J 1/16W		R270			RK73GB1J272J	CHIP R 2.7K J 1/16W	
R122,123			R92-1252-05	CHIP R 0 OHM J 1/16W		R271			RK73GB1J561J	CHIP R 560 J 1/16W	
R124			RK73GB1J473J	CHIP R 47K J 1/16W		R272			RK73GB1J152J	CHIP R 1.5K J 1/16W	
R125-128			RK73GB1J102J	CHIP R 1.0K J 1/16W		R273			RK73GB1J472J	CHIP R 4.7K J 1/16W	
R129			R92-1252-05	CHIP R 0 OHM J 1/16W		R274,275			RK73GB1J153J	CHIP R 15K J 1/16W	
R130,131			RK73GB1J102J	CHIP R 1.0K J 1/16W		R276			RK73GB1J473J	CHIP R 47K J 1/16W	
R151			RK73GB1J103J	CHIP R 10K J 1/16W		R277			RK73GB1J683J	CHIP R 68K J 1/16W	
R152			RK73GB1J472J	CHIP R 4.7K J 1/16W		R278			RK73GB1J123J	CHIP R 12K J 1/16W	
R161			RK73GB1J122J	CHIP R 1.2K J 1/16W		R279			RK73GB1J472J	CHIP R 4.7K J 1/16W	
R162			RK73GB1J152J	CHIP R 1.5K J 1/16W		R280			RK73GB1J391J	CHIP R 390 J 1/16W	
R163			RK73GB1J473J	CHIP R 47K J 1/16W		R281			R92-0670-05	CHIP R 0 OHM	
R164-166			RK73GB1J102J	CHIP R 1.0K J 1/16W		R301,302			RK73GB1J472J	CHIP R 4.7K J 1/16W	
R201			RK73GB1J681J	CHIP R 680 J 1/16W		R303			RK73GB1J223J	CHIP R 22K J 1/16W	
R202			R92-0670-05	CHIP R 0 OHM		R304			RK73GB1J472J	CHIP R 4.7K J 1/16W	
R203			RK73GB1J104J	CHIP R 100K J 1/16W		R305			RK73GB1J182J	CHIP R 1.8K J 1/16W	
R204			RK73GB1J183J	CHIP R 18K J 1/16W		R306			RK73GB1J274J	CHIP R 270K J 1/16W	
R205			RK73GB1J821J	CHIP R 820 J 1/16W		R308			RK73GB1J334J	CHIP R 330K J 1/16W	
R206			RK73GB1J101J	CHIP R 100 J 1/16W		R309			RK73GB1J332J	CHIP R 3.3K J 1/16W	
R207			RK73GB1J754J	CHIP R 750K J 1/16W		R310			RK73GB1J102J	CHIP R 1.0K J 1/16W	
R208			RK73GB1J152J	CHIP R 1.5K J 1/16W		R311			RK73GB1J333J	CHIP R 33K J 1/16W	
R209			RK73GB1J244J	CHIP R 240K J 1/16W		R312			RK73GB1J473J	CHIP R 47K J 1/16W	
R210			RK73GB1J183J	CHIP R 18K J 1/16W		R313			RK73GB1J104J	CHIP R 100K J 1/16W	
R211,212			RK73GB1J823J	CHIP R 82K J 1/16W		R314			RK73GB1J222J	CHIP R 2.2K J 1/16W	
R213			RK73GB1J334J	CHIP R 330K J 1/16W		R315			RK73GB1J183J	CHIP R 18K J 1/16W	
R214,215			RK73GB1J683J	CHIP R 68K J 1/16W		R316			RK73GB1J223J	CHIP R 22K J 1/16W	
R216			RK73GB1J274J	CHIP R 270K J 1/16W		R317-320			RK73GB1J103J	CHIP R 10K J 1/16W	
R217			RK73GB1J224J	CHIP R 220K J 1/16W		R321			RK73GB1J223J	CHIP R 22K J 1/16W	

PARTS LIST / 零件表

TX-RX UNIT (X57-6913-01)

Ref. No.	Address	New parts	Parts No.	Description	Destination	Ref. No.	Address	New parts	Parts No.	Description	Destination
R322			RK73GB1J101J	CHIP R 100 J 1/16W		R437			RK73GB1J102J	CHIP R 1.0K J 1/16W	
R323			RK73GB1J224J	CHIP R 220K J 1/16W		R438			RK73GB1J223J	CHIP R 22K J 1/16W	
R324			R92-1252-05	CHIP R 0 OHM J 1/16W		R439			RK73GB1J473J	CHIP R 47K J 1/16W	
R325			RK73GB1J333J	CHIP R 33K J 1/16W		R440-442			RK73GB1J101J	CHIP R 100 J 1/16W	
R349			RK73GB1J473J	CHIP R 47K J 1/16W		R443			RK73GB1J222J	CHIP R 2.2K J 1/16W	
R350			RK73GB1J273J	CHIP R 27K J 1/16W		R444			RK73GB1J102J	CHIP R 1.0K J 1/16W	
R351			RK73GB1J471J	CHIP R 470 J 1/16W		R501			RK73GB1J102J	CHIP R 1.0K J 1/16W	
R352			RK73GB1J101J	CHIP R 100 J 1/16W		R502			RK73GB1J271J	CHIP R 270 J 1/16W	
R353			RK73GB1J104J	CHIP R 100K J 1/16W		R503			RK73GB1J180J	CHIP R 18 J 1/16W	
R354			RK73GB1J331J	CHIP R 330 J 1/16W		R504			RK73GB1J271J	CHIP R 270 J 1/16W	
R355			RK73GB1J471J	CHIP R 470 J 1/16W		R505			RK73GB1J222J	CHIP R 2.2K J 1/16W	
R356			RK73GB1J102J	CHIP R 1.0K J 1/16W		R506			RK73GB1J103J	CHIP R 10K J 1/16W	
R358			RK73GB1J470J	CHIP R 47 J 1/16W		R507			RK73GB1J100J	CHIP R 10 J 1/16W	
R359			RK73GB1J224J	CHIP R 220K J 1/16W		R508			RK73GB1J222J	CHIP R 2.2K J 1/16W	
R360			RK73GB1J474J	CHIP R 470K J 1/16W		R509			RK73GB1J330J	CHIP R 33 J 1/16W	
R361			RK73GB1J470J	CHIP R 47 J 1/16W		R510			RK73GB1J152J	CHIP R 1.5K J 1/16W	
R362			RK73GB1J474J	CHIP R 470K J 1/16W		R511			RK73FB2A470J	CHIP R 47 J 1/10W	
R363			RK73GB1J154J	CHIP R 150K J 1/16W		R512			RK73FB2A100J	CHIP R 10 J 1/10W	
R364			R92-1252-05	CHIP R 0 OHM J 1/16W		R513			RK73FB2A222J	CHIP R 2.2K J 1/10W	
R365			RK73GB1J104J	CHIP R 100K J 1/16W		R514			R92-0686-05	CHIP R 33 J 1/2W	
R366			RK73GB1J471J	CHIP R 470 J 1/16W		R515			RK73FB2A221J	CHIP R 220 J 1/10W	
R367			RK73GB1J470J	CHIP R 47 J 1/16W		R516			RK73FB2A220J	CHIP R 22 J 1/10W	
R368			RK73GB1J104J	CHIP R 100K J 1/16W		R517			RK73FB2A221J	CHIP R 220 J 1/10W	
R369			R92-1252-05	CHIP R 0 OHM J 1/16W		R518			RK73EB2B470J	CHIP R 47 J 1/8W	
R370			RK73GB1J151J	CHIP R 150 J 1/16W		R519			RK73GB1J822J	CHIP R 8.2K J 1/16W	
R371			RK73GB1J474J	CHIP R 470K J 1/16W		R520			RK73GB1J102J	CHIP R 1.0K J 1/16W	
R372			RK73GB1J224J	CHIP R 220K J 1/16W		R521			RK73GB1J101J	CHIP R 100 J 1/16W	
R373			RK73GB1J684J	CHIP R 680K J 1/16W		R522			R92-1252-05	CHIP R 0 OHM J 1/16W	
R374			RK73GB1J184J	CHIP R 180K J 1/16W		R526			R92-1261-05	CHIP R 150 J 1/2W	
R375,376			RK73GB1J104J	CHIP R 100K J 1/16W		R527			RK73GB1J334J	CHIP R 330K J 1/16W	
R378			R92-1252-05	CHIP R 0 OHM J 1/16W		R528,529			RK73GB1J103J	CHIP R 10K J 1/16W	
R379			RK73GB1J104J	CHIP R 100K J 1/16W		R530			RK73GB1J392J	CHIP R 3.9K J 1/16W	
R401-403			RK73GB1J102J	CHIP R 1.0K J 1/16W		R531			RK73GB1J473J	CHIP R 47K J 1/16W	
R404			RK73GB1J103J	CHIP R 10K J 1/16W		R532,533			R92-1252-05	CHIP R 0 OHM J 1/16W	
R405			R92-1252-05	CHIP R 0 OHM J 1/16W		R601,602			RK73GB1J223J	CHIP R 22K J 1/16W	
R407			RK73GB1J152J	CHIP R 1.5K J 1/16W		R603			RK73GB1J473J	CHIP R 47K J 1/16W	
R408			RK73GB1J100J	CHIP R 10 J 1/16W		R605			RK73GB1J473J	CHIP R 47K J 1/16W	
R409			RK73GB1J104J	CHIP R 100K J 1/16W		R606			RK73GB1J102J	CHIP R 1.0K J 1/16W	
R410			RK73GB1J822J	CHIP R 8.2K J 1/16W		R800			R92-1061-05	JUMPER REST 0 OHM	
R411			RK73GB1J562J	CHIP R 5.6K J 1/16W		D1-11			DA221	DIODE	
R412,413			RK73GB1J103J	CHIP R 10K J 1/16W		D31			ZSH5MA27	SURGE ABSORBER	
R414			RK73GB1J471J	CHIP R 470 J 1/16W		D32			1812L110PR	VARIATOR	
R415			R92-1252-05	CHIP R 0 OHM J 1/16W		D61			02DZ18(X,Y)	ZENER DIODE	
R416			RK73GB1J471J	CHIP R 470 J 1/16W		D201			DAN222	DIODE	
R417			RK73GB1J224J	CHIP R 220K J 1/16W		D202			1SS372	DIODE	
R418,419			RK73GB1J102J	CHIP R 1.0K J 1/16W		D251			MA742	DIODE	
R420			RK73GB1J272J	CHIP R 2.7K J 1/16W		D301			MA742	DIODE	
R421			RK73GB1J152J	CHIP R 1.5K J 1/16W		D302,303			DAN222	DIODE	
R422			RK73GB1J103J	CHIP R 10K J 1/16W		D351-354			HVC350B	VARIABLE CAPACITANCE DIODE	
R423,424			RK73GB1J221J	CHIP R 220 J 1/16W		D401			MA2S111	DIODE	
R425,426			RK73GB1J473J	CHIP R 47K J 1/16W		D402			HZU5ALL	DIODE	
R427			RK73GB1J104J	CHIP R 100K J 1/16W		D403-406			MA2S304	VARIABLE CAPACITANCE DIODE	
R428			RK73GB1J473J	CHIP R 47K J 1/16W		D407			MA360	VARIABLE CAPACITANCE DIODE	
R429,430			RK73GB1J101J	CHIP R 100 J 1/16W		D408			MA2S111	DIODE	
R431			RK73GB1J104J	CHIP R 100K J 1/16W		D409			DAN235E	DIODE	
R432			RK73GB1J102J	CHIP R 1.0K J 1/16W		D501			1SS355	DIODE	
R433			RK73GB1J472J	CHIP R 4.7K J 1/16W		D502			DA221	DIODE	
R434			R92-1252-05	CHIP R 0 OHM J 1/16W		D503			02DZ5.1(Y)	ZENER DIODE	
R435			RK73GB1J101J	CHIP R 100 J 1/16W		D602			MA4PH633	DIODE	
R436			RK73GB1J124J	CHIP R 120K J 1/16W							

PARTS LIST / 零件表

TX-RX UNIT (X57-6913-01)

Ref. No.	Address	New parts	Parts No.	Description	Destination	Ref. No.	Address	New parts	Parts No.	Description	Destination
D603			XB15A709	DIODE							
D606,607			MA742	DIODE							
D608,609			1SS355	DIODE							
IC31			KIA7808AF	ANALOG IC							
IC32,33			NJM78L05UA	BI-POLAR IC							
IC34,35			PST9140NR	MOS IC							
IC66		*	AT24C64A10S118	ROM IC							
IC101		*	30622MAA-B87GP	MPU							
IC161			M62363FP	MOS IC							
IC201			NJM2100V	MOS IC							
IC202			NJM2904V	MOS IC							
IC203			NJM2902V	MOS IC							
IC251			NJM2902V	MOS IC							
IC252	2B		LA46000	BI-POLAR IC							
IC301			TK14489V	BI-POLAR IC							
IC401			MB15A02	MOS IC							
IC402			UPB1509GV	BI-POLAR IC							
IC501			TA75W01FU	MOS IC							
IC502	2B		RA30H1317M-31	MOS IC							
Q1			2SK1824	FET							
Q31	2B		KAT1046(Y)	TRANSISTOR							
Q32			2SK1824	FET							
Q33			2SA1745(6,7)	TRANSISTOR							
Q34			KRC102S	DIGITAL TRANSISTOR							
Q35			KTA1664(Y)	TRANSISTOR							
Q36			KRC102S	DIGITAL TRANSISTOR							
Q61			KRC404RTK	DIGITAL TRANSISTOR							
Q71			KRC414RTK	DIGITAL TRANSISTOR							
Q86,87			2SK1824	FET							
Q201			2SC4919	TRANSISTOR							
Q202			2SJ243	FET							
Q251			2SC4617(S)	TRANSISTOR							
Q252,253			2SK1824	FET							
Q254			DTC363EU	DIGITAL TRANSISTOR							
Q255			KRC102S	DIGITAL TRANSISTOR							
Q301			2SC2412K	TRANSISTOR							
Q302			2SC4617(S)	TRANSISTOR							
Q351			2SC5108(Y)	TRANSISTOR							
Q352,353			3SK255	FET							
Q354			2SK1824	FET							
Q402			2SA1832(GR)	TRANSISTOR							
Q403			2SC4738(GR)	TRANSISTOR							
Q404			2SC4649(N,P)	TRANSISTOR							
Q405,406			2SK508NV(K52)	FET							
Q407			2SJ243	FET							
Q408			KRX102U	TRANSISTOR							
Q410			2SC5108(Y)	TRANSISTOR							
Q411			2SC4649(N,P)	TRANSISTOR							
Q440			2SC4617(S)	TRANSISTOR							
Q501,502			2SC3357	TRANSISTOR							
TH97,98			B57331V2104J	THERMISTOR							
TH301			B57331V2104J	THERMISTOR							

TK-7108

EXPLODED VIEW / 部件分解图

- A M3 x 8 : N67-3008-46
- B M2.6 x 6 (Br-Tap) : N87-2606-46
- C M2.6 x 14 (Br-Tap) : N87-2614-46

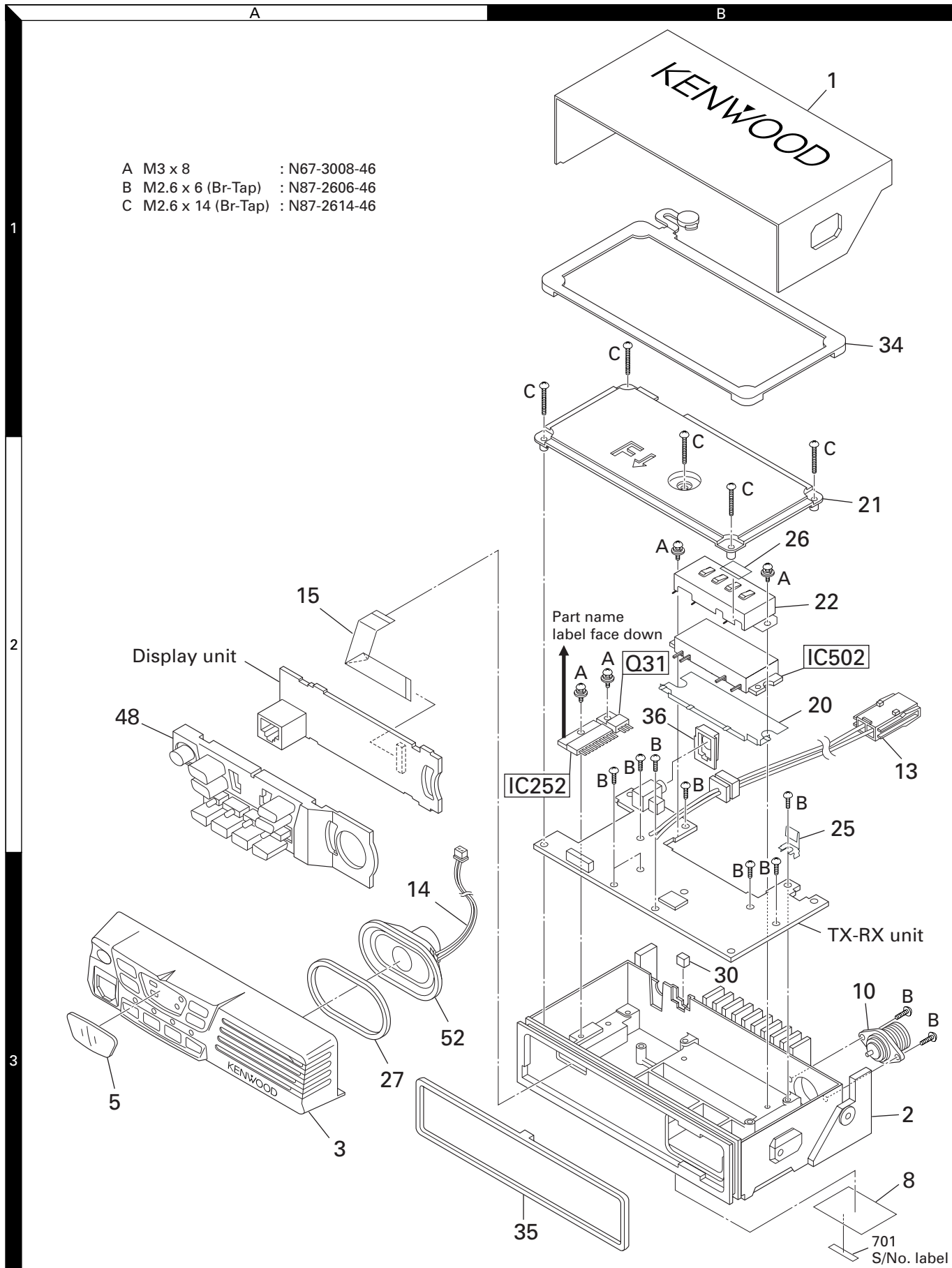

Parts with the exploded numbers larger than 700 are not supplied.

PACKING (M TYPE) / 包装 (M类型)

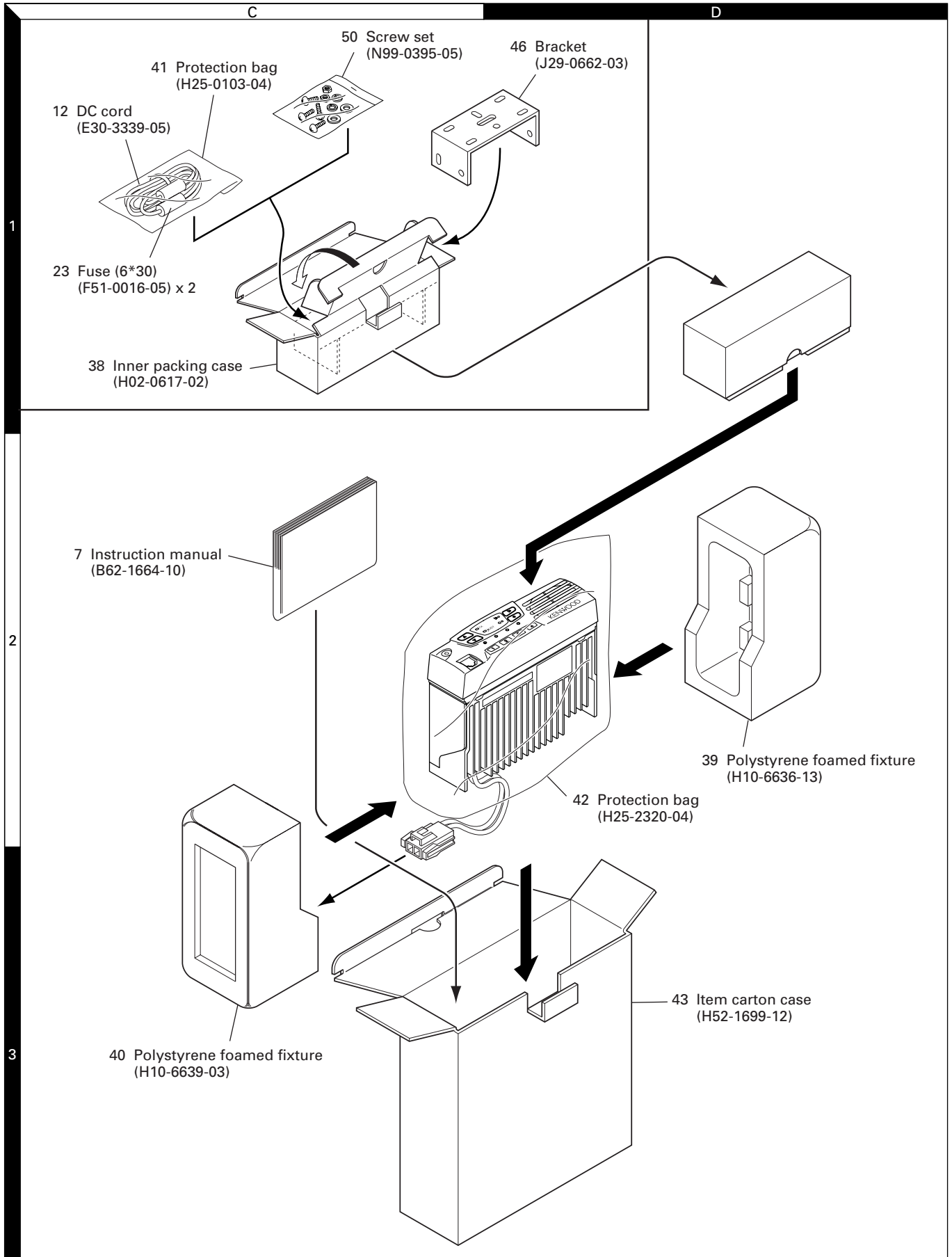

Parts with the exploded numbers larger than 700 are not supplied.

PACKING (C TYPE) / 包装 (C类型)

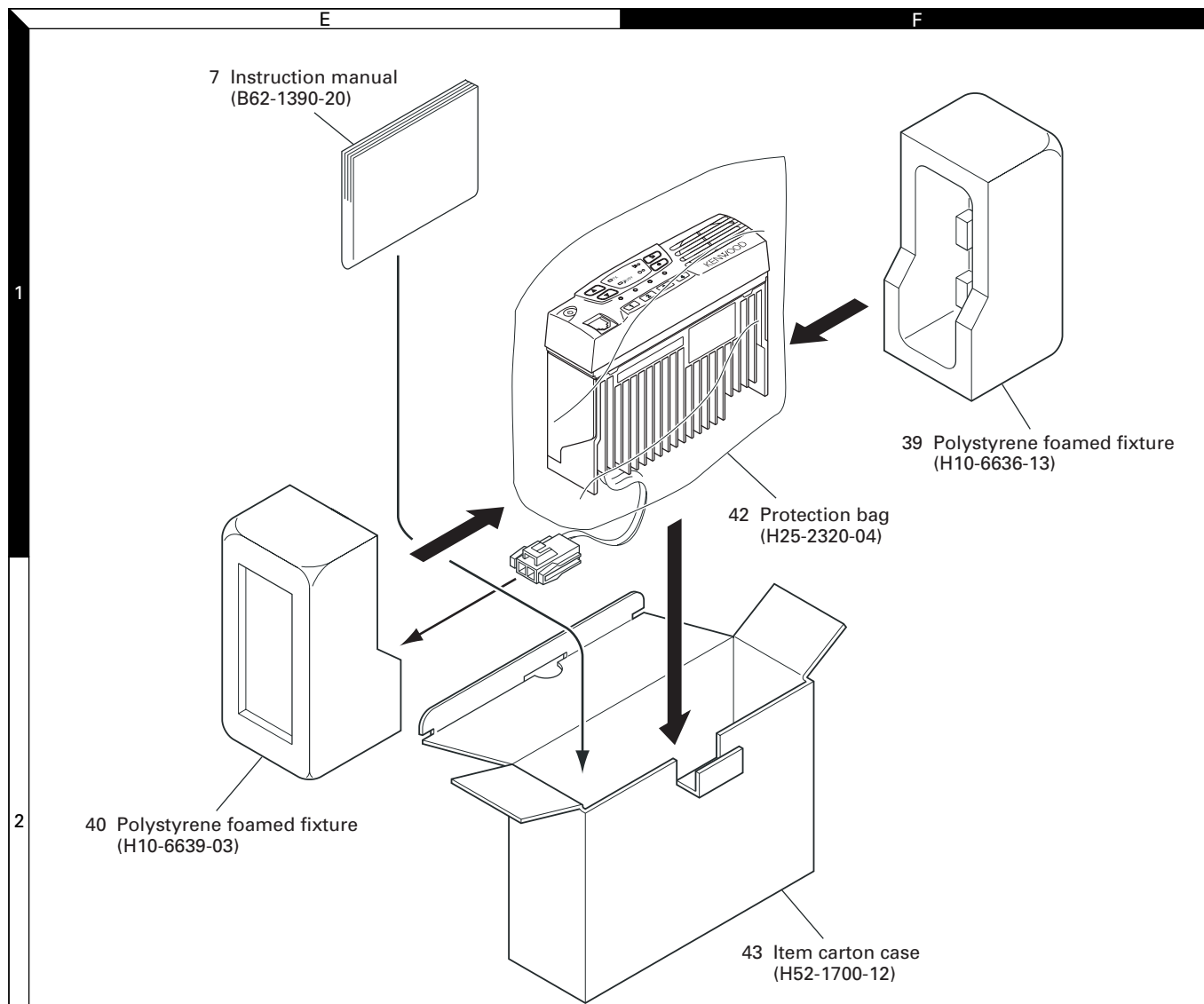

KMB-19 (Installation kit)

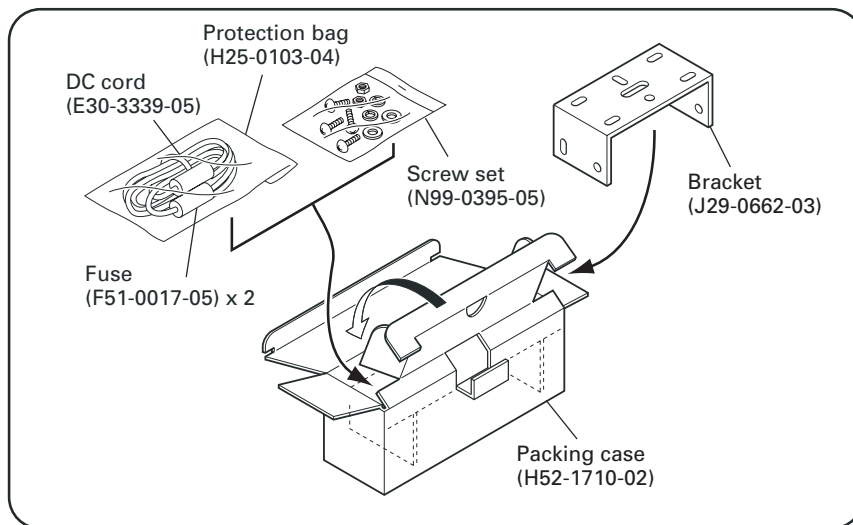

ADJUSTMENT

Test Equipment Required for Alignment

Test Equipment	Major Specifications	
1. Standard Signal Generator (SSG)	Frequency Range Modulation Output	136 to 175MHz Frequency modulation and external modulation -127dBm/0.1μV to greater than -7dBm/100mV
2. Power Meter	Input Impedance Operation Frequency Measurement Capability	50Ω 136 to 175MHz or more Vicinity of 100W
3. Deviation Meter	Frequency Range	136 to 175MHz
4. Digital Volt Meter (DVM)	Measuring Range Accuracy	1 to 20V DC High input impedance for minimum circuit loading
5. Oscilloscope		DC through 30MHz
6. High Sensitivity Frequency Counter	Frequency Range Frequency Stability	10Hz to 1000MHz 0.2ppm or less
7. Ammeter		20A
8. AF Volt Meter (AF VTVM)	Frequency Range Voltage Range	50Hz to 10kHz 1mV to 3V
9. Audio Generator (AG)	Frequency Range Output	20Hz to 20kHz or more 0 to 1V
10. Distortion Meter	Capability Input Level	3% or less at 1kHz 50mV to 10Vrms
11. 4Ω Dummy Load		Approx. 4Ω, 10W or more
12. Regulated Power Supply		13.6V, approx. 20A (adjustable from 9 to 17V) Useful if ammeter reequipped
13. Spectrum Analyzer	Center frequency	50KHz to 600MHz
14. Tracking Generator	Output Voltage	100mV or more

Test cable for microphone input (E30-3360-08)

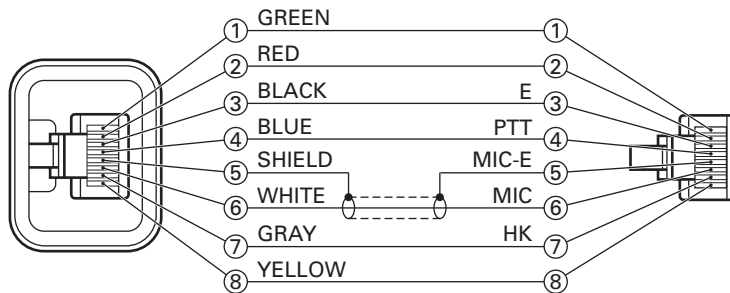

MIC connector (Front view)

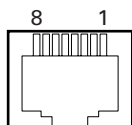

- 1 : BLC
- 2 : PSB
- 3 : E
- 4 : PTT
- 5 : ME
- 6 : MIC
- 7 : HOOK
- 8 : CM

Tuning cable (E30-3383-05)

Adapter cable (E30-3383-05) is required for injecting an audio if PC tuning is used. See "PC Mode" section for the connection.

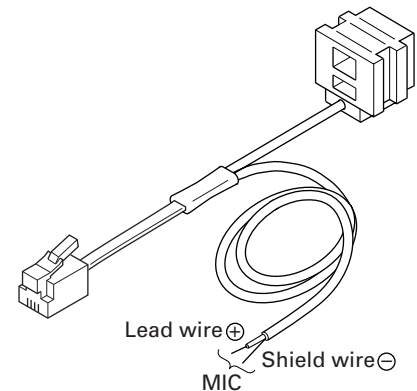

Test Frequency (MHz)

Channel	TX	RX
1 : Center	160.100	160.050
2 : Low	146.100	146.050
3 : High	173.900	173.950
4	160.000	160.000
5	160.200	160.200
6	160.400	160.400

调 整

所需的用于调整的测试设备

测试设备	主要特性
1. 标准信号发生器 (SSG)	频率范围 136到175MHz 调制 调频和外部调制 输出 -127dBm/0.1 μ V到大于 -7dBm/100mV
2. 功率计	输入阻抗 50 Ω 工作频率 135到175MHz或更高 测量范围 100W左右
3. 偏差仪	频率范围 136到175MHz
4. 数字电压表 (DVM)	测量范围 直流1V到20V 输入阻抗 最小电路负载时为高输入阻抗
5. 示波器	直流到30MHz
6. 高灵敏度频率计数器	频率范围 10Hz到1000MHz 频率稳定性 0.2ppm或更低
7. 电流表	20A
8. 音频电压表 (AF VTVM)	频率范围 50Hz到10kHz 电压范围 1mV到3V
9. 音频发生器 (AG)	频率范围 20Hz到20kHz或更高 输出 0到1V
10. 失真测试仪	测量能力 在1kHz时3%或更低 输入电平 50mV到10Vrms
11. 4 Ω 假负载	大约4 Ω , 10W或更高
12. 可调电源	13.6V, 大约20A (adjustable from 9 to 17V) 最好具备电流表
13. 频谱分析仪	中心频率 50kHz到600MHz
14. 轨迹发生器	输出电压 100mV或更高

用于麦克风输入的测试电缆 (E30-3360-08)

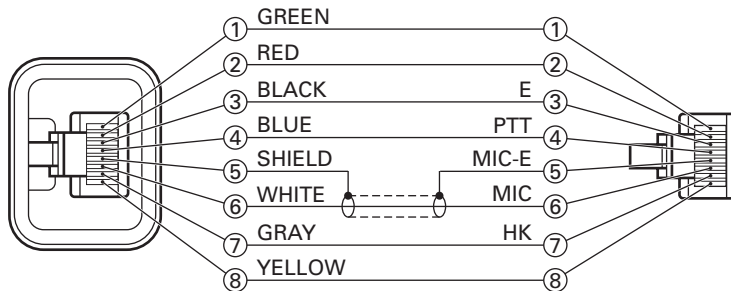

话筒连接器 (前视)

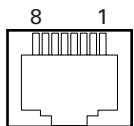

- 1: BLC
- 2: PSB
- 3: E
- 4: PTT
- 5: ME
- 6: MIC
- 7: HOOK
- 8: CM

调谐电缆 (E30-3383-05)

如果使用计算机调谐, 接头电缆 (E30-3383-05) 将用于接入音频信号。
参见“计算机模式”章节有关连接的内容。

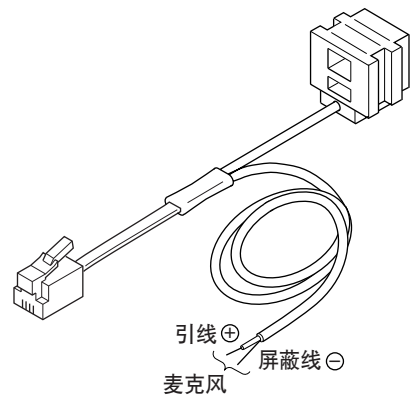

测试频率 (MHz)

信道	发射	接收
1: 中心	160.100	160.050
2: 低	146.100	146.050
3: 高	173.900	173.950
4	160.000	160.000
5	160.200	160.200
6	160.400	160.400

ADJUSTMENT / 调整

Adjustment Location / 调整定位

■ Switch / 开关

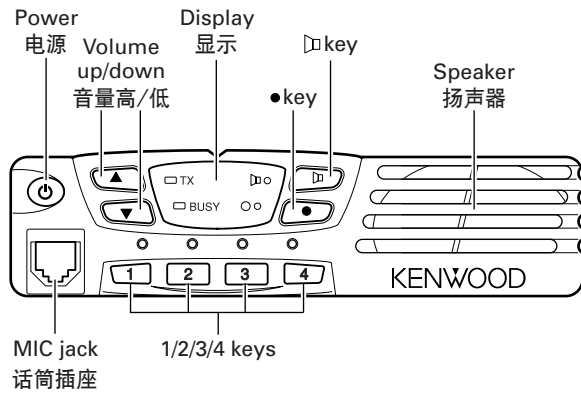

■ Adjustment Points / 调整点

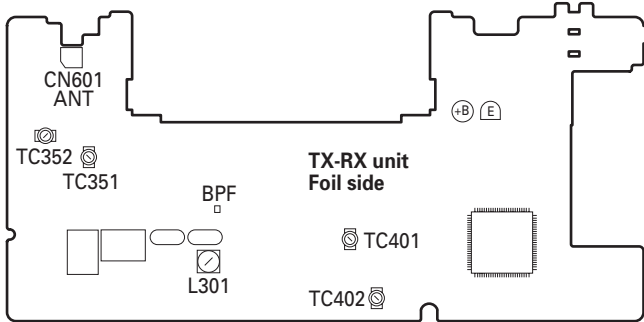
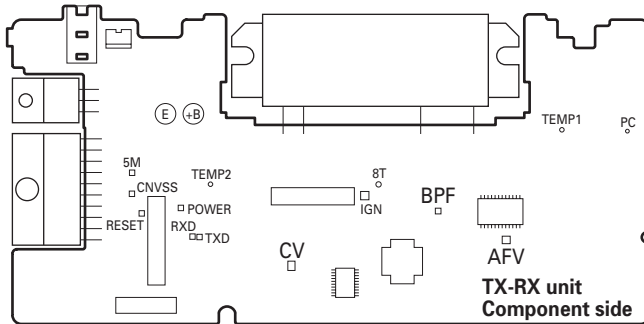

■ Notes

• EEPROM

The tuning data (Deviation, Squelch, etc.) for the EEPROM, is stored in memory. When parts are changed, re-adjust the transceiver.

• EEPROM

EEPROM的调谐数据(偏差, 静噪等等)被储存在存储器中。当零件被改变时, 调整通信机。

• AF PA IC (IC252)

How to mounting the IC252.

• 音频放大器 (IC252)

IC252安装方法。

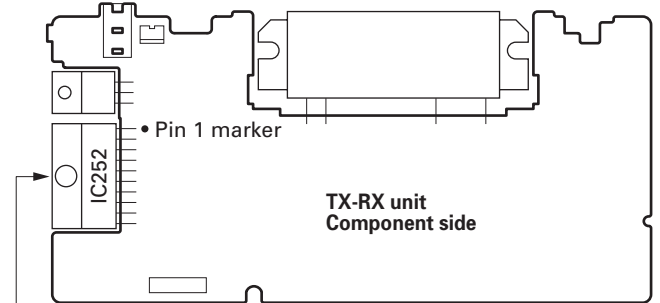

Part name label face down / 部件名称标签向下

• Speaker Cable

The speaker cable should be formed before mounting the shield cover as below.

• 扬声器电缆

安装屏蔽罩前, 按如下所示整理扬声器电缆。

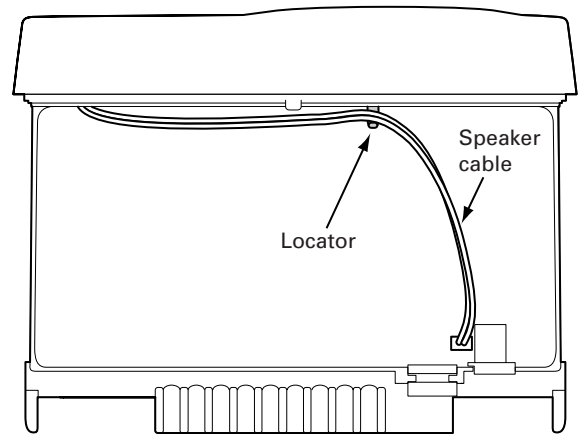

• Fuse

To mount the fuse, the cable terminal direction must be as follow.

• 熔丝

安装熔丝, 电缆端子方向必须为如下所示。

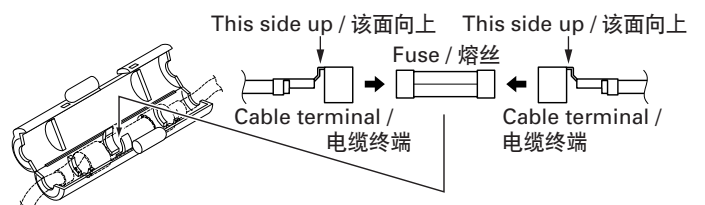

ADJUSTMENT

PCB Section

Item	Condition	Measurement		Adjustment		Specifications/ Remarks
		Test equipment	Terminal	Parts	Method	
1. Setting	1) Power supply voltage DC Power supply terminal : 13.6V					
2. VCO lock voltage	1) CH : TX high	Digital voltmeter	CV	TC402	5.5V	±0.1V
	2) CH : RX high			TC401	5.5V	±0.1V
	3) CH : TX low				Check	0.7V or more
	4) CH : RX low					
3. IF coil	1) CH : RX center (Wide) 2) SSG output : -53dBm (501μV) Mod : 1kHz Dev : 3kHz	SSG Digital voltmeter	AFV	L301	3.25~3.35V (DC)	
4. RF bandpass filter	1) CH : RX center (Wide) CH : RX low (Wide) CH : RX high (Wide) 2) Track generator output : -30dBm Connect the spectrum analyzer to BPF terminal	Track generator Spectrum analyzer	ANT BPF	TC351 TC352	Adjust the BPF waveform to Fig. 1	

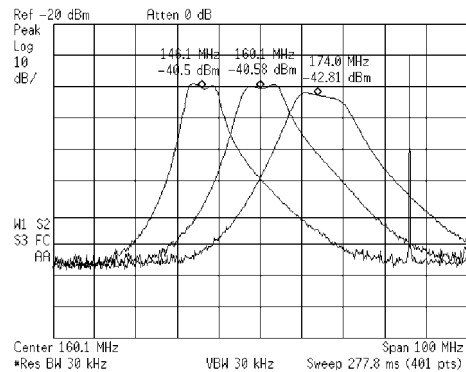

Fig. 1

Receiver Section

Item	Condition	Measurement		Adjustment		Specifications/ Remarks
		Test equipment	Terminal	Parts	Method	
1. Sensitivity	1) CH : RX low (Wide/Narrow) CH : RX center (Wide/Narrow) CH : RX high (Wide/Narrow) 2) SSG output : -118dBm (0.28μV) (Wide) : -116dBm (0.35μV) (Narrow) Mod : 1kHz Dev : ±3.0kHz (Wide) Dev : ±1.5kHz (Narrow)	SSG Oscilloscope AF V.M Distortion meter	ANT EXT. SP		Check	SINAD : 12dB or higher
2. Squelch 9	1) CH : RX low (Wide) CH : RX center (Wide/Narrow) CH : RX high (Wide) 2) SSG output : -115dBm (0.4μV) (Wide) : -114dBm (0.45μV) (Narrow) Mod : 1kHz Dev : ±3.0kHz (Wide) Dev : ±1.5kHz (Narrow)			PC key	Adjust to open the squelch	

调 整

PCB部分

项 目	条 件	测 量		调 整		规格 / 备注
		测试设备	终端	部件	方 法	
1. 设定	1) 电源电压 直流电源终端：13.6V					
2. 压控振荡器电压	1) CH：发射高频点	数字电压表	CV	TC402	5.5V	± 0.1V
	2) CH：接收高频点			TC401	5.5V	± 0.1V
	3) CH：发射低频点				检查	0.7V或更高
	4) CH：接收低频点					
3. IF coil	1) 接收中频点(宽) 2) 标准信号发生器输出： -53dBm (501μV) 调制：1kHz 频偏：3kHz	SSG 数字电压表	AFV	L301	3.25 ~ 3.35V (DC)	
4. RF带 电滤波器	1) CH：接收中频点(宽) CH：接收低频点(宽) CH：接收高频点(宽) 2) 轨迹发生器输出：-30dBm 连接频率分析仪到BPF终端	轨迹发生器 频谱分析仪	天线 BPF	TC351 TC352	按图1调整BPF波形	



图1

接收部分

项 目	条 件	测 量		调 整		规格 / 备注
		测试设备	终端	部件	方 法	
1. 灵敏度	1) CH：接收低频点(宽/窄) CH：接收中心频点(宽/窄) CH：接收高频点(宽/窄) 2) 标准信号发生器输出： - 118dBm (0.28μV) (宽) - 116dBm (0.35μV) (窄) 调制：1kHz 频偏：± 3.0kHz (宽) 频偏：± 1.5kHz (窄)	SSG 示波器 AF V.M 失真测试仪	天线 外部扬声器		检查	SINAD ：12dB或更高
2. 静噪抑制 电路9	1) CH：接收低频点(宽) CH：接收中心频点(宽/窄) CH：接收高频点(宽) 2) 标准信号发生器输出： - 115dBm (0.4μV) (宽) - 114dBm (0.45μV) (窄) 调制：1kHz 频偏：± 3.0kHz (宽) 频偏：± 1.5kHz (窄)			PC机键	经调整打开静噪	

ADJUSTMENT

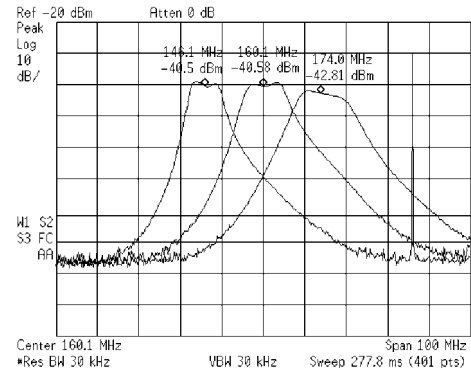
Item	Condition	Measurement		Adjustment		Specifications/ Remarks
		Test equipment	Terminal	Parts	Method	
3. Squelch 1	1) CH : RX low (Wide) CH : RX center (Wide/Narrow) CH : RX high (Wide) 2) SSG output : -120dBm (0.22μV) (Wide) : -119dBm (0.25μV) (Narrow) Mod : 1kHz Dev : ±3.0kHz (Wide) Dev : ±1.5kHz (Narrow)			PC key	Adjust to open the squelch	

Transmitter Section

Item	Condition	Measurement		Adjustment		Specifications/ Remarks
		Test equipment	Terminal	Parts	Method	
1. Frequency	1) CH : TX center 2) Transmit	Frequency counter	ANT	PC key	Adjust to center frequency	Within ±100Hz
2. Maximum power check	1) CH : TX high 2) Transmit	Power meter			28W Hex data 255	±1W
3. High power	1) CH : TX low CH : TX low' CH : TX center CH : TX high' CH : TX high 2) Transmit				25W	±1.0W
4. Low power	1) CH : TX low CH : TX low' CH : TX center CH : TX high' CH : TX high 2) Transmit				5W	±1.0W
5. DQT balance	1) CH : TX low (Wide) CH : TX center (Wide/Narrow) CH : TX high (Wide) 2) Transmit				Modulation analyzer or Linear detector (LPF : 3kHz) Oscilloscope	
6. MAX balance	1) CH : TX low (Wide) CH : TX center (Wide/Narrow) CH : TX high (Wide) 2) AG : 1kHz/50mV 3) Transmit	Modulation analyzer or Linear detector (LPF : 15kHz) Oscilloscope AG AF V.M	ANT MIC		±4.0kHz (Wide) ±2.0kHz (Narrow) According to the large +, -	±50Hz
7. MIC sensitivity	1) CH : TX center (Wide/Narrow) 2) AG : 1kHz/5mV 3) Transmit				Check	±3kHz±0.2kHz (Wide) ±1.5kHz±0.1kHz (Narrow)
8. DQT deviation	1) CH : TX low (Wide) CH : TX center (Wide/Narrow) CH : TX high (Wide) 2) Transmit	Modulation analyzer or Linear detector (LPF : 3kHz) Oscilloscope			±0.75kHz (Wide) ±0.35kHz (Narrow)	±0.05kHz
9. QT deviation	1) CH : TX low (Wide) CH : TX center (Wide/Narrow) CH : TX high (Wide) 2) Transmit				±0.75kHz (Wide) ±0.35kHz (Narrow)	±0.05kHz
10. DTMF deviation	1) CH : TX center (Wide/Narrow) 2) Transmit				±3.0kHz (Wide) ±1.5kHz (Narrow)	±0.2kHz

调 整

项 目	条 件	测 量		调 整		规格 / 备注
		测试设备	终 端	部 件	方 法	
3. 静噪抑制电路1	1) CH: 接收低频点 (宽) CH: 接收中心频点 (宽/窄) CH: 接收高频点 (宽) 2) 标准信号发生器输出 : -120dBm (0.22 μ V) (宽) : -119dBm (0.25 μ V) (窄) 调制: 1kHz 频偏: ± 3.0 kHz (宽) 频偏: ± 1.5 kHz (窄)			PC机键	经调整打开静噪	

发射部分

项 目	条 件	测 量		调 整		规格 / 备注
		测试设备	终 端	部 件	方 法	
1. 频率	1) CH: 发射中心频点 2) 发射	频率计数器	天线	PC机键	调整中心频率	± 100 Hz以内
2. 最大功率检查	1) CH: 发射高频点 2) 发射	功率表		PC机键	28W Hex data 255	± 1 W
3. 高功率	1) CH: 发射低频点 CH: 发射低频点' CH: 发射中心频点 CH: 发射高频点' CH: 发射高频点 2) 发射				25W	± 1.0 W
4. 低功率	1) CH: 发射低频点 CH: 发射低频点' CH: 发射中心频点 CH: 发射高频点' CH: 发射高频点 2) 发射				5W	± 1.0 W
5. DQT平衡	1) CH: 发射低频点 (宽) CH: 发射中心频点 (宽/窄) CH: 发射高频点 (宽) 2) 发射				频谱分析仪 或线性失真检测 (LPF: 3kHz) 示波器	
6. 最大平衡	1) CH: 发射低频点 (宽) CH: 发射中心频点 (宽/窄) CH: 发射高频点 (宽) 2) AG: 1kHz/50mV 3) 发射	频谱分析仪 或线性失真检测 (LPF: 15kHz) 示波器 AG AF V.M	天线 MIC		± 4.0 kHz (宽) ± 2.0 kHz (窄) 按照较大+, -	± 50 Hz
7. 调制灵敏度	1) CH: 发射中心频点 (宽/窄) 2) AG: 1kHz/5mV 3) 发射				检查	± 3 kHz ± 0.2 kHz (宽) ± 1.5 kHz ± 0.1 kHz (窄)
8. DQT频偏	1) CH: 发射低频点 (宽) CH: 发射中心频点 (宽/窄) CH: 发射高频点 (宽) 2) 发射	频谱分析仪 或线性失真检测 (LPF: 3kHz) 示波器			± 0.75 kHz (宽) ± 0.35 kHz (窄)	± 0.05 kHz
9. QT频偏	1) CH: 发射低频点 (宽) CH: 发射中心频点 (宽/窄) CH: 发射高频点 (宽) 2) 发射				± 0.75 kHz (宽) ± 0.35 kHz (窄)	± 0.05 kHz
10. DTMF频偏	1) CH: 发射中心频点 (宽/窄) 2) 发射				± 3.0 kHz (宽) ± 1.5 kHz (窄)	± 0.2 kHz

TERMINAL FUNCTION

CN1

No.	Name	I/O	Function
1	DI		Data
2	CL		Clock
3	CE		Chip enable
4	5C		5V
5	SB		Switched B
6	KMO2	O	Key matrix output 2
7	KMI4	I	Key matrix input 4
8	KMO1	O	Key matrix output 1
9	KMI3	I	Key matrix input 3
10	KMI1	I	Key matrix input 1
11	CM		MIC data detection
12	KMI2	I	Key matrix input 2
13	HOOK		Hook detection/RXD
14	ME		MIC ground
15	POWER		Power switch
16	MIC	I	MIC signal input
17	PTT		PTT/TXD
18	GND		Ground

CN2

No.	Name	I/O	Function
1	SB	O	Battery voltage DC supply
2	NC	-	-
3	GND	O	Ground
4	DETO2	O	FM detector output
5	FNC1	I/O	Programable I/O (programmed by FPU)
6	FNC2	I/O	Programable I/O (programmed by FPU)
7	FNC3	I/O	Programable I/O (programmed by FPU)
8	FNC4	I/O	Programable I/O (programmed by FPU)
9	FNC5	I/O	Programable I/O (programmed by FPU)
10	FNC6	I/O	Programable I/O (programmed by FPU)
11	FNC7	I/O	Programable I/O (programmed by FPU)
12	FNC8	I/O	Programable I/O (programmed by FPU)

Function Port Assignment

KDS100, KGP-2A/2B		
	Name	I/O
FNC1	-	-
FNC2	-	-
FNC3	Data Channel	I
FNC4	PTT	I
FNC5	Carrier Operated Relay	O
FNC6	Audio Mute	I
FNC7	Mic Mute	I
FNC8	TX Relay	O
SmarTrunk II		
	Name	I/O
FNC1	TXD	O
FNC2	RXD	I
FNC3	Reset	O
FNC4	-	-
FNC5	-	-
FNC6	-	-
FNC7	-	-
FNC8	-	-
Scrambler		
	Name	I/O
FNC1	-	-
FNC2	-	-
FNC3	TX Relay	O
FNC4	Scrambler	O
FNC5	Scrambler Code1 (1)	O
FNC6	Scrambler Code2 (2)	O
FNC7	Scrambler Code3 (4)	O
FNC8	Scrambler Code4 (8)	O

Port Function is Low Active. (Exclude : Scrambler Code)

CN3

No.	Name	I/O	Function
1	IGN	I	Ignition sens input
2	DATAI	I	External transmit signal input
3	DETO	O	FM detector output
4	TXAFI	I	TX audio input from scrambler board
5	TXAFO	O	TX audio output to scrambler board
6	EMGMIC	I	Emergency MIC input (1kHz/1.2mVrms)
7	RXAFO	O	RX audio output to scrambler board
8	ALTI	I	External alert tone signal input
9	RXAFI	I	RX audio input from scrambler board
10	5C	O	5V DC power supply (50mA MAX)
11	8C	O	8V DC power supply (50mA MAX)

端子功能

CN1

No.	名称	I/O	功能
1	DI		数据
2	CL		时钟
3	CE		芯片有效
4	5C		5V
5	SB		转换的B+
6	KMO2	O	按键矩阵输出2
7	KMI4	I	按键矩阵输入4
8	KMO1	O	按键矩阵输出1
9	KMI3	I	按键矩阵输入3
10	KMI1	I	按键矩阵输入1
11	CM		麦克风数据检测
12	KMI2	I	按键矩阵输入2
13	HOOK		接通检测/RXD
14	ME		麦克风接地
15	POWER		电源开关
16	MIC	I	麦克风信输入
17	PTT		PTT/TXD
18	GND		接地

CN2

No.	名称	I/O	功能
1	SB	O	电池电压DC电源
2	NC	-	-
3	GND	O	接地
4	DETO2	O	FM检测器输出
5	FNC1	I/O	可编程的I/O (由FPU编程)
6	FNC2	I/O	可编程的I/O (由FPU编程)
7	FNC3	I/O	可编程的I/O (由FPU编程)
8	FNC4	I/O	可编程的I/O (由FPU编程)
9	FNC5	I/O	可编程的I/O (由FPU编程)
10	FNC6	I/O	可编程的I/O (由FPU编程)
11	FNC7	I/O	可编程的I/O (由FPU编程)
12	FNC8	I/O	可编程的I/O (由FPU编程)

■功能端口分配

KDS100, KGP-2A/2B		
	名称	I/O
FNC1	-	-
FNC2	-	-
FNC3	数据信道	I
FNC4	PTT	I
FNC5	载波状态输出	O
FNC6	音频静音	I
FNC7	麦克风静音	I
FNC8	TX状态输出	O
SmarTrunk II		
	名称	I/O
FNC1	TXD	O
FNC2	RXD	I
FNC3	复位	O
FNC4	-	-
FNC5	-	-
FNC6	-	-
FNC7	-	-
FNC8	-	-
扰频器		
	名称	I/O
FNC1	-	-
FNC2	-	-
FNC3	TX状态输出	O
FNC4	扰频器	O
FNC5	扰频器代码1 (1)	O
FNC6	扰频器代码2 (2)	O
FNC7	扰频器代码3 (4)	O
FNC8	扰频器代码4 (8)	O

端口功能为低电平有效。(除：扰频器代码)

CN3

No.	名称	I/O	功能
1	IGN	I	点火传感器信号输入
2	DATAI	I	外部设备发射信号输入
3	DETO	O	FM检测器输出
4	TXAFI	I	从扰频器板输入的TX音频
5	TXAFO	O	TX音频输出到扰频器板
6	EMGMIC	I	紧急报警MIC输入 (1kHz/1.2mVrms)
7	RXAFO	O	RX音频输出到扰频器板
8	ALTI	I	外部报警音信号输入
9	RXAFI	I	从扰频器板输入的RX音频
10	5C	O	5V DC电源 (最大50mA)
11	8C	O	8V DC电源 (最大50mA)

TK-7108 PC BOARD / PC板

DISPLAY UNIT (X54-3460-20) Component side view (J72-0916-09)

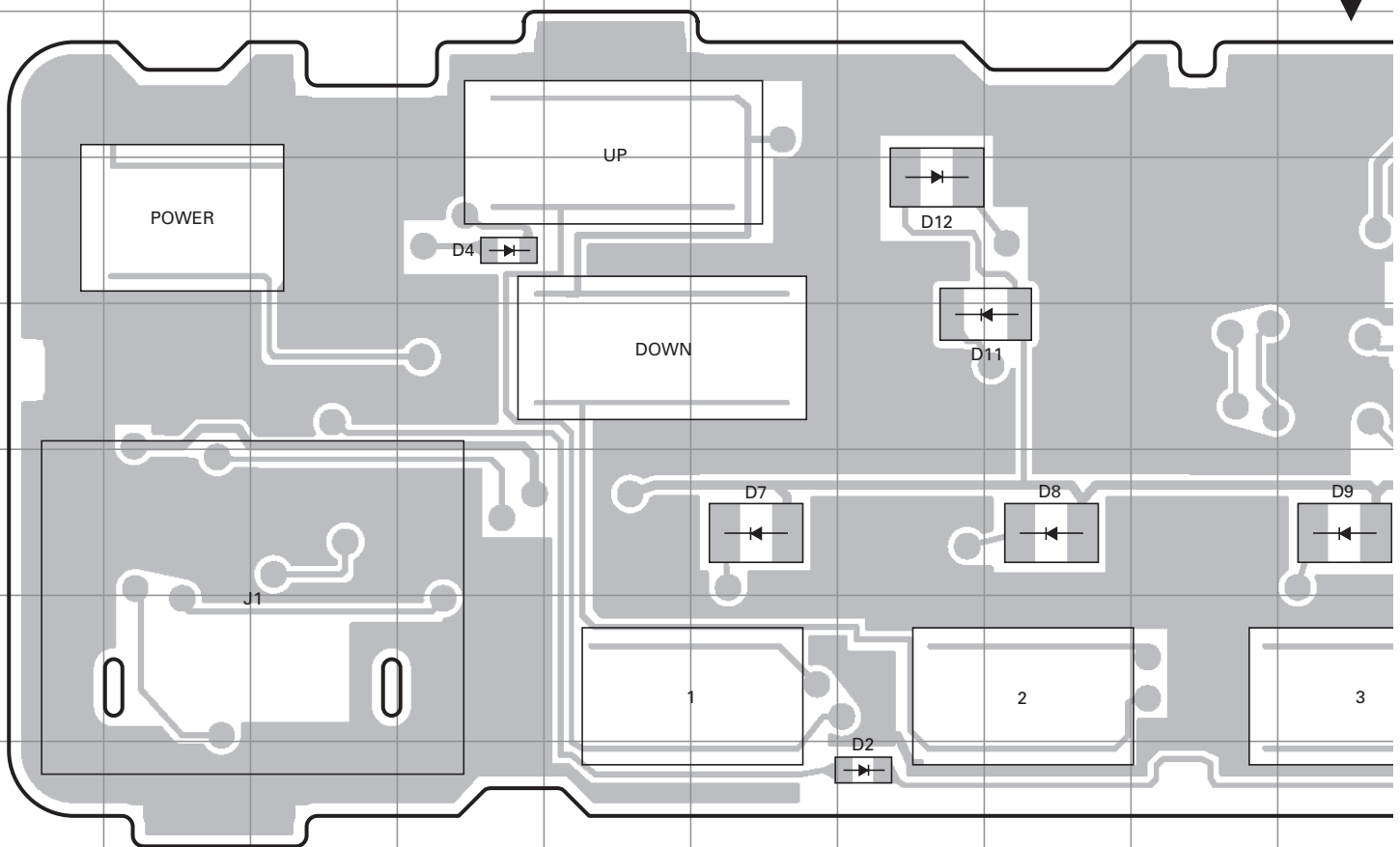

DISPLAY UNIT (X54-3460-20) Foil side view (J72-0916-09)

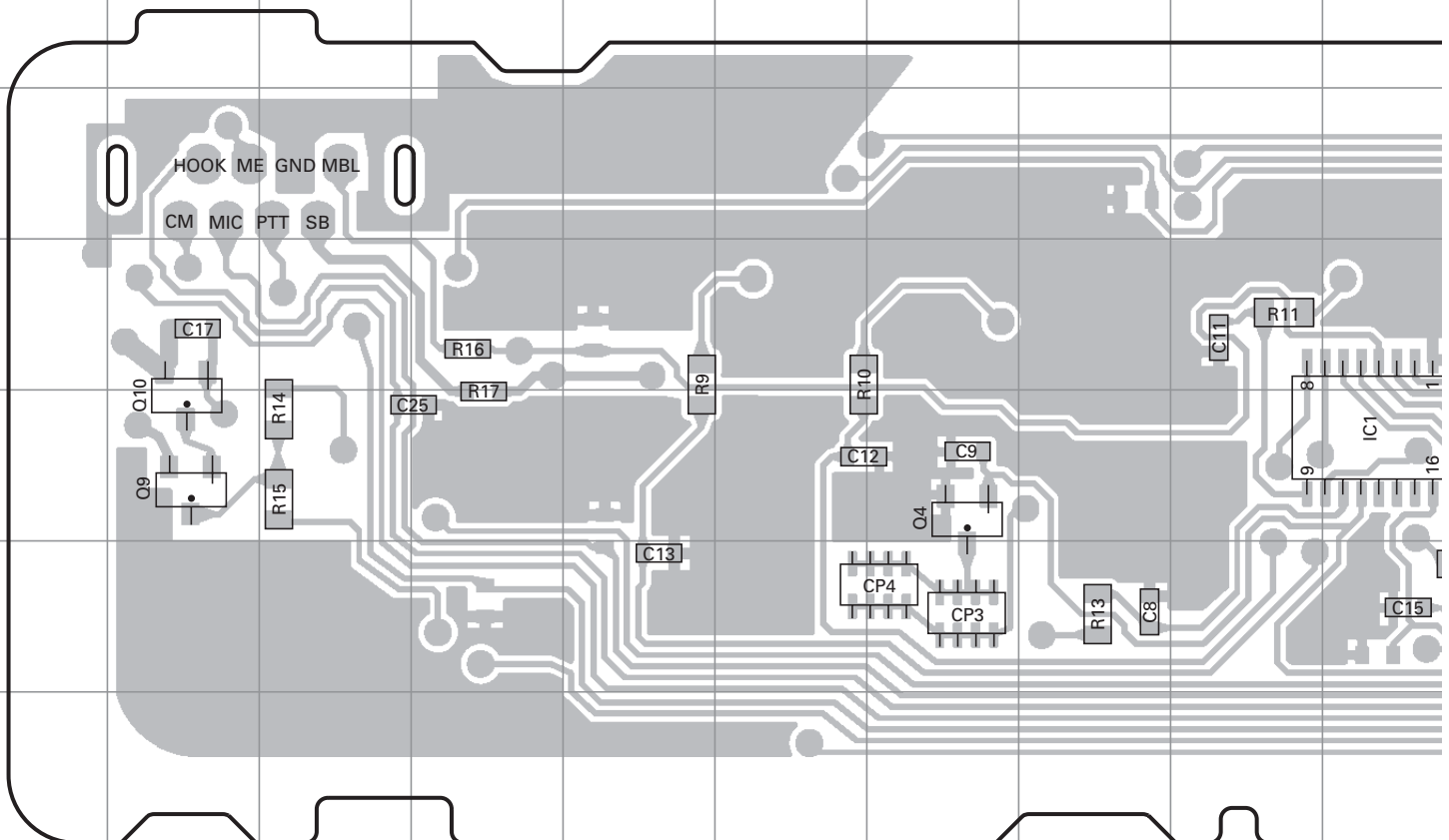

PC BOARD / PC板 TK-7108

DISPLAY UNIT (X54-3460-20) Component side view (J72-0916-09)

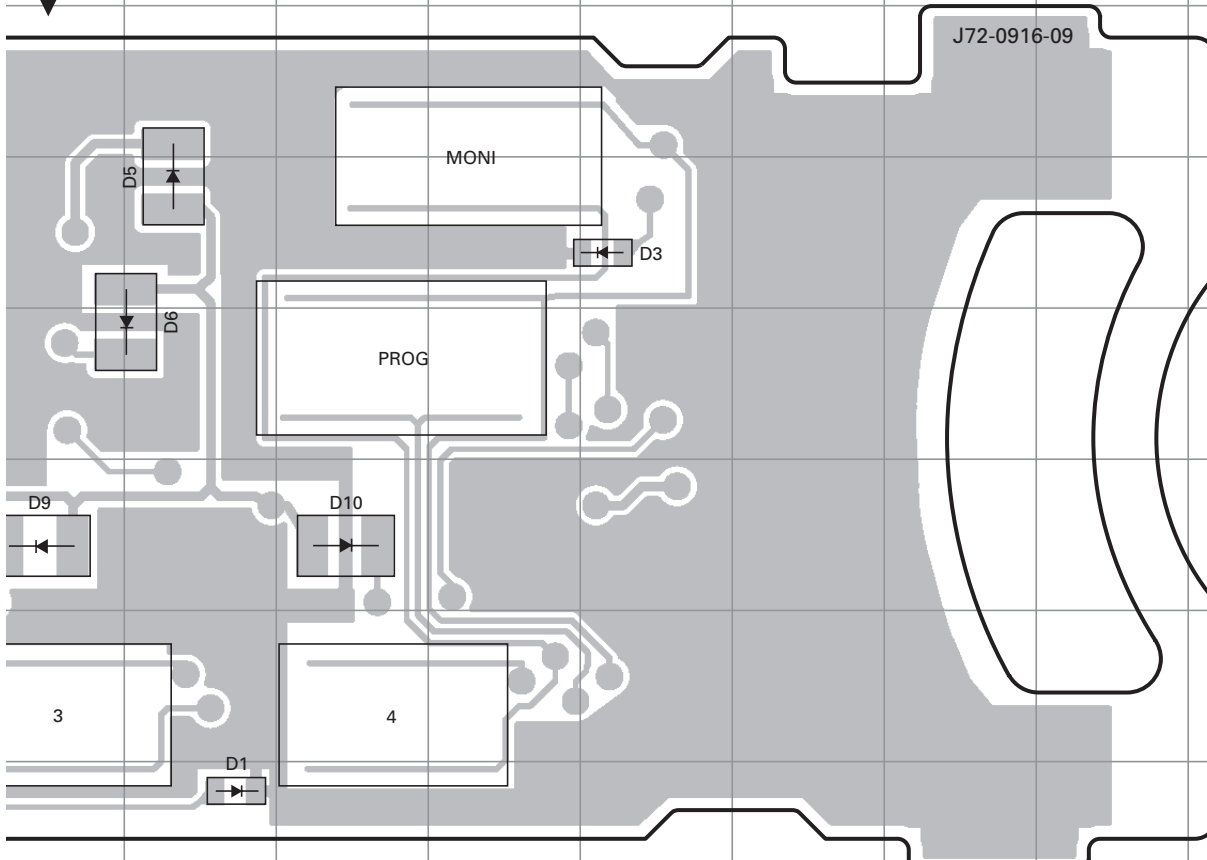

Ref. No.	Address
D1	7K
D2	7G
D3	3N
D4	3D
D5	3K
D6	4K
D7	5F
D8	5H
D9	5J
D10	5L
D11	4H
D12	3G

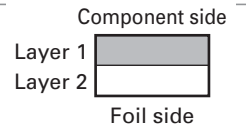

DISPLAY UNIT (X54-3460-20) Foil side view (J72-0916-09)

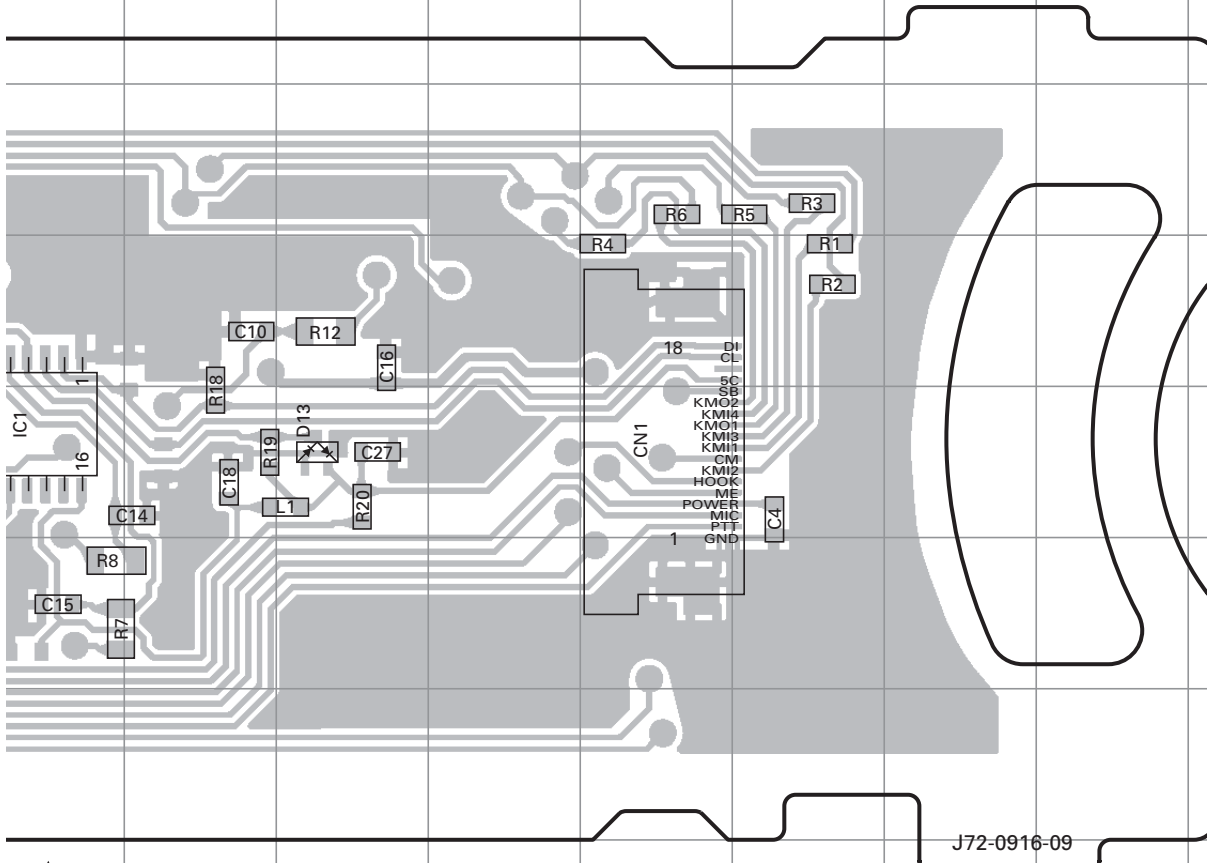

Ref. No.	Address
IC1	11J
Q4	11G
Q9	11B
Q10	11B
D13	11L

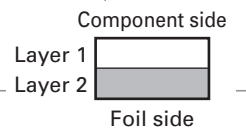

TK-7108 PC BOARD / PC板

DISPLAY UNIT (X54-3460-20) Component side view (J72-0916-09)

PC BOARD / PC板 TK-7108

DISPLAY UNIT (X54-3460-20) Component side view (J72-0916-09)

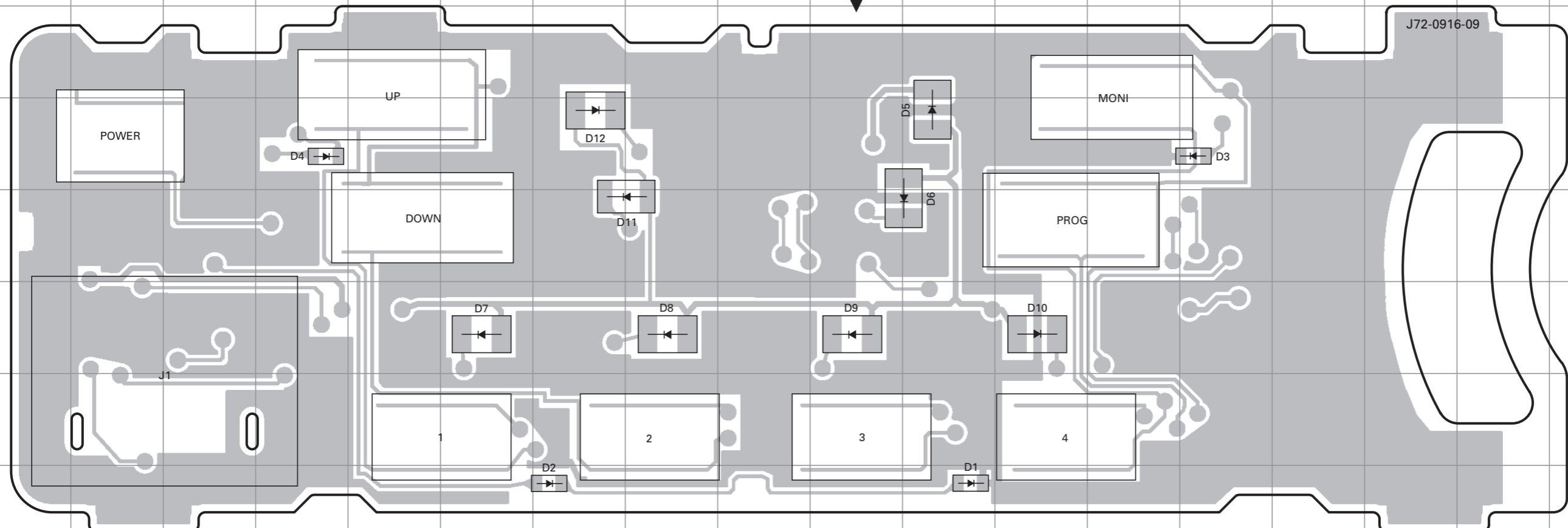

Ref. No.	Address
D1	7K
D2	7G
D3	3N
D4	3D
D5	3K
D6	4K
D7	5F
D8	5H
D9	5J
D10	5L
D11	4H
D12	3G

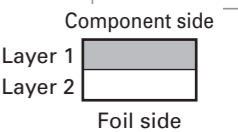

DISPLAY UNIT (X54-3460-20) Foil side view (J72-0916-09)

DISPLAY UNIT (X54-3460-20) Foil side view (J72-0916-09)

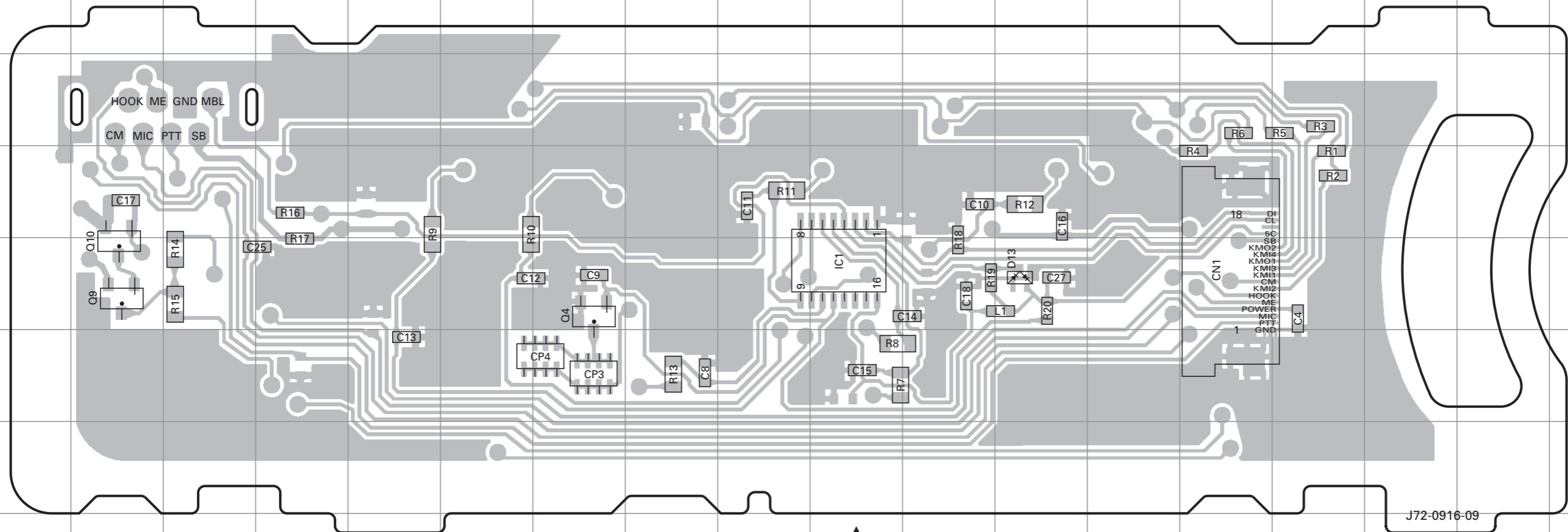

Ref. No.	Address
IC1	11J
Q4	11G
Q9	11B
Q10	11B
D13	11L

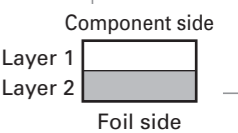

TK-7108 PC BOARD / PC板

TX-RX UNIT (X57-6913-01) Component side view (J72-0917-09)

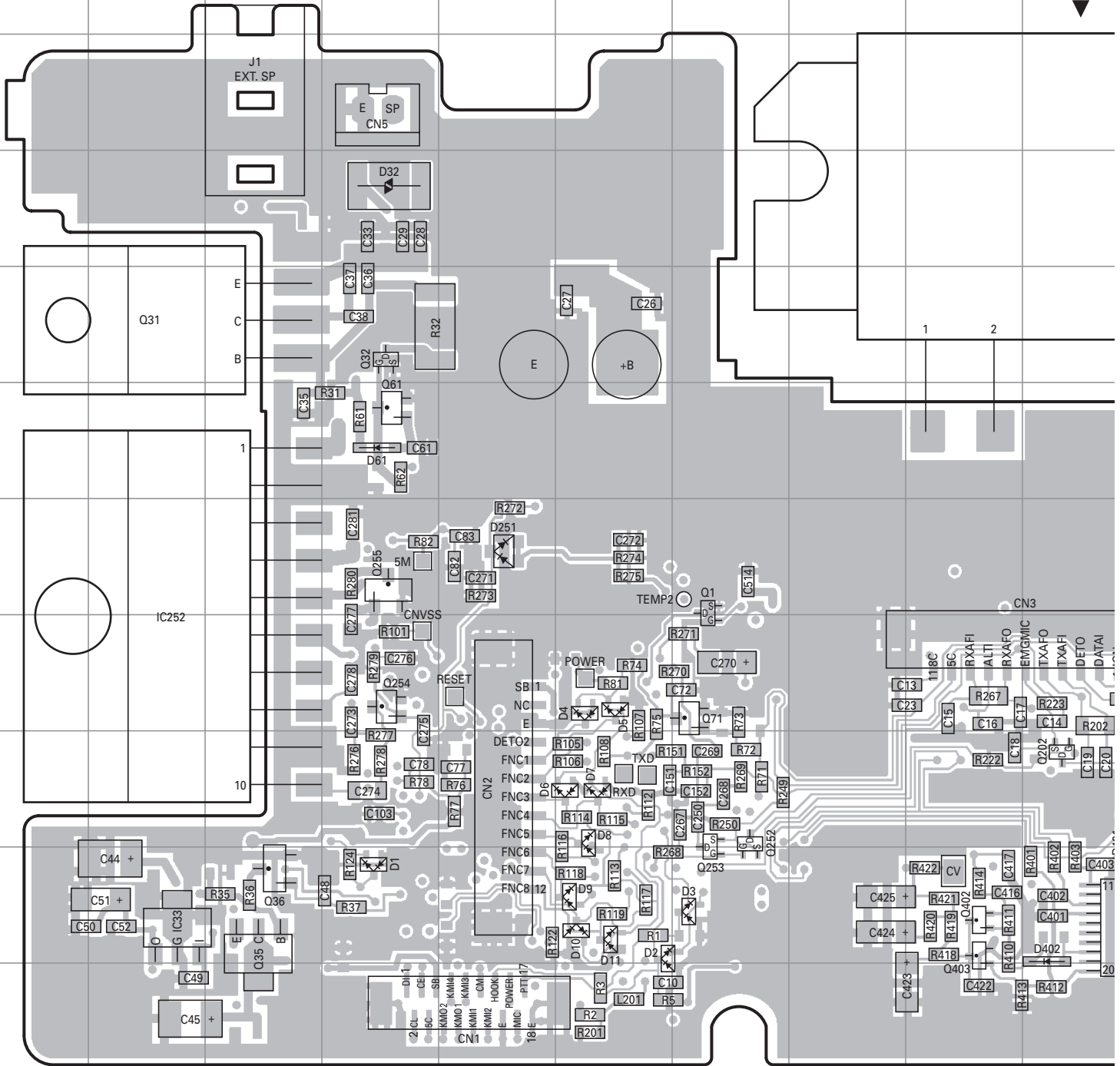

Ref. No.	Address	Ref. No.	Address	Ref. No.	Address	Ref. No.	Address	Ref. No.	Address	Ref. No.	Address	Ref. No.	Address
IC33	10B	IC502	4K	Q201	8P	Q354	7Q	D6	9F	D201	8P	D607	4P
IC161	8O	Q1	7G	Q202	9J	Q402	10I	D7	9F	D202	7P	D608	5R
IC201	8R	Q31	5B	Q252	9G	Q403	10I	D8	9F	D251	7E	D609	6S
IC202	8R	Q32	5D	Q253	10G	D1	10D	D9	10F	D302	10P		
IC203	10R	Q35	10C	Q254	8D	D2	10F	D10	10F	D303	9Q		
IC252	8B	Q36	10C	Q255	7D	D3	10G	D11	10F	D401	10J		
IC401	10J	Q61	6D	Q302	11L	D4	8F	D32	4D	D402	10J		
IC501	6R	Q71	8G	Q351	10O	D5	8F	D61	6D	D606	5P		

TK-7108 PC BOARD / PC板

TX-RX UNIT (X57-6913-01)
Foil side view (J72-0917-09)

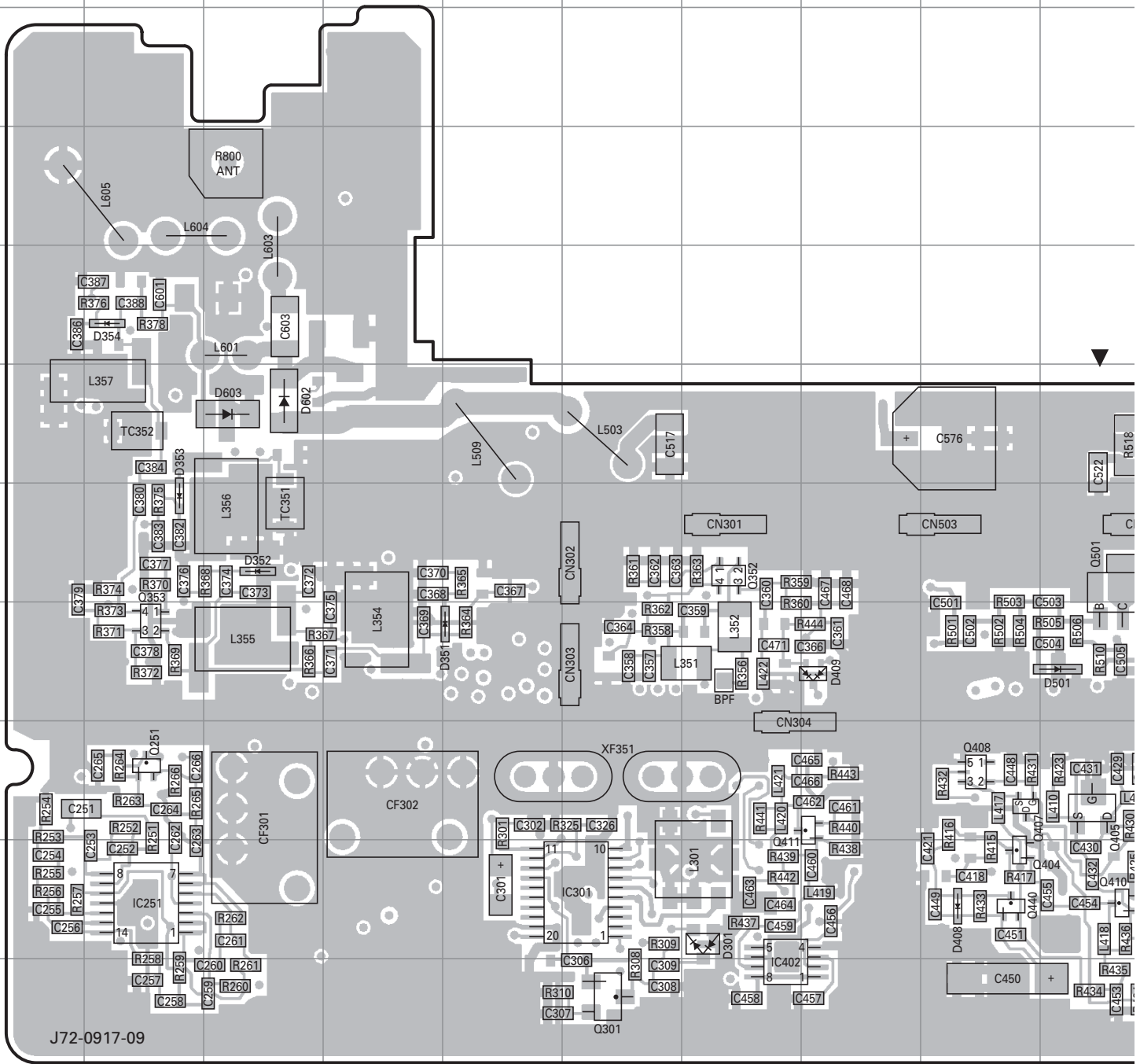

J72-0917-09

Ref. No.	Address	Ref. No.	Address	Ref. No.	Address	Ref. No.	Address	Ref. No.	Address	Ref. No.	Address
IC31	10R	IC402	11G	Q353	8B	Q440	10I	D354	5B	D501	8J
IC32	11Q	Q33	10Q	Q404	10I	Q501	7J	D403	9L	D502	8K
IC34	11N	Q34	10Q	Q405	9J	Q502	8L	D404	9K	D503	6K
IC35	10M	Q86	8O	Q406	10K	D31	4O	D405	10L	D602	6C
IC66	9M	Q87	8P	Q407	9I	D301	10G	D406	10L	D603	6C
IC101	9O	Q251	9B	Q408	9I	D351	8E	D407	10L		
IC251	10B	Q301	11F	Q410	10J	D352	7C	D408	10I		
IC301	10F	Q352	7G	Q411	9H	D353	7B	D409	8H		

PC BOARD / PC板 TK-7108

TX-RX UNIT (X57-6913-01)
Foil side view (J72-0917-09)

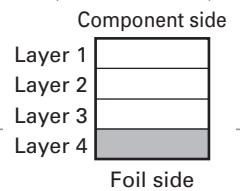
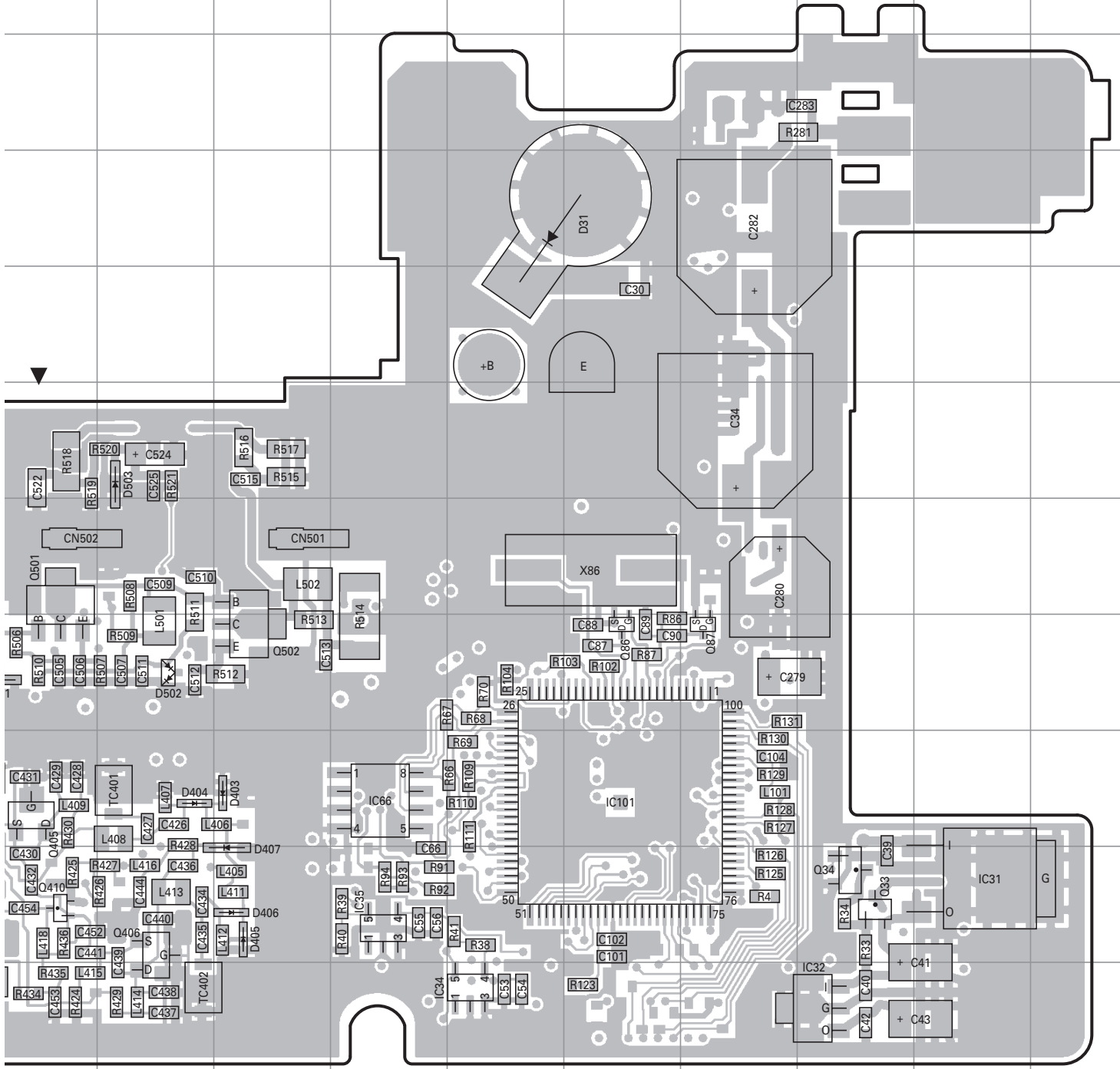

TK-7108 PC BOARD / PC板

PC BOARD / PC板 TK-7108

TX-RX UNIT (X57-6913-01)
Foil side view (J72-0917-09)

TX-RX UNIT (X57-6913-01)
Foil side view (J72-0917-09)

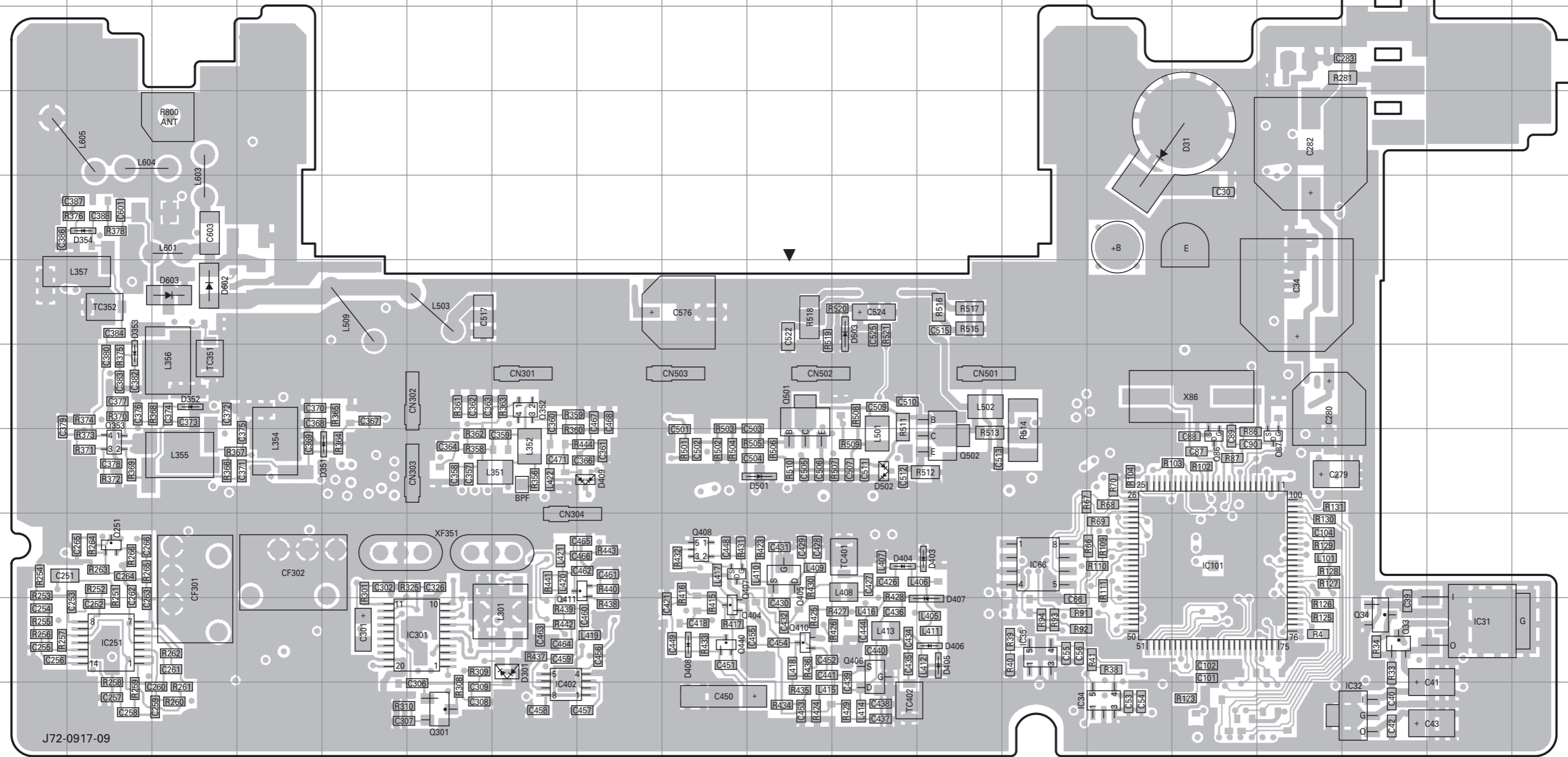

J72-0917-09

Ref. No.	Address	Ref. No.	Address	Ref. No.	Address	Ref. No.	Address	Ref. No.	Address	Ref. No.	Address
IC31	10R	IC402	11G	Q353	8B	Q440	10I	D354	5B	D501	8J
IC32	11Q	Q33	10Q	Q404	10I	Q501	7J	D403	9L	D502	8K
IC34	11N	Q34	10Q	Q405	9J	Q502	8L	D404	9K	D503	6K
IC35	10M	Q86	8O	Q406	10K	D31	4O	D405	10L	D602	6C
IC66	9M	Q87	8P	Q407	9I	D301	10G	D406	10L	D603	6C
IC101	9O	Q251	9B	Q408	9I	D351	8E	D407	10L		
IC251	10B	Q301	11F	Q410	10J	D352	7C	D408	10I		
IC301	10F	Q352	7G	Q411	9H	D353	7B	D409	8H		

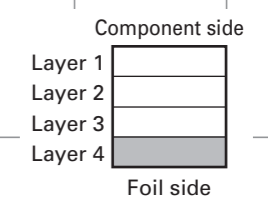

TK-7108 SCHEMATIC DIAGRAM / 原理图

TX-RX UNIT (X57-6913-01)

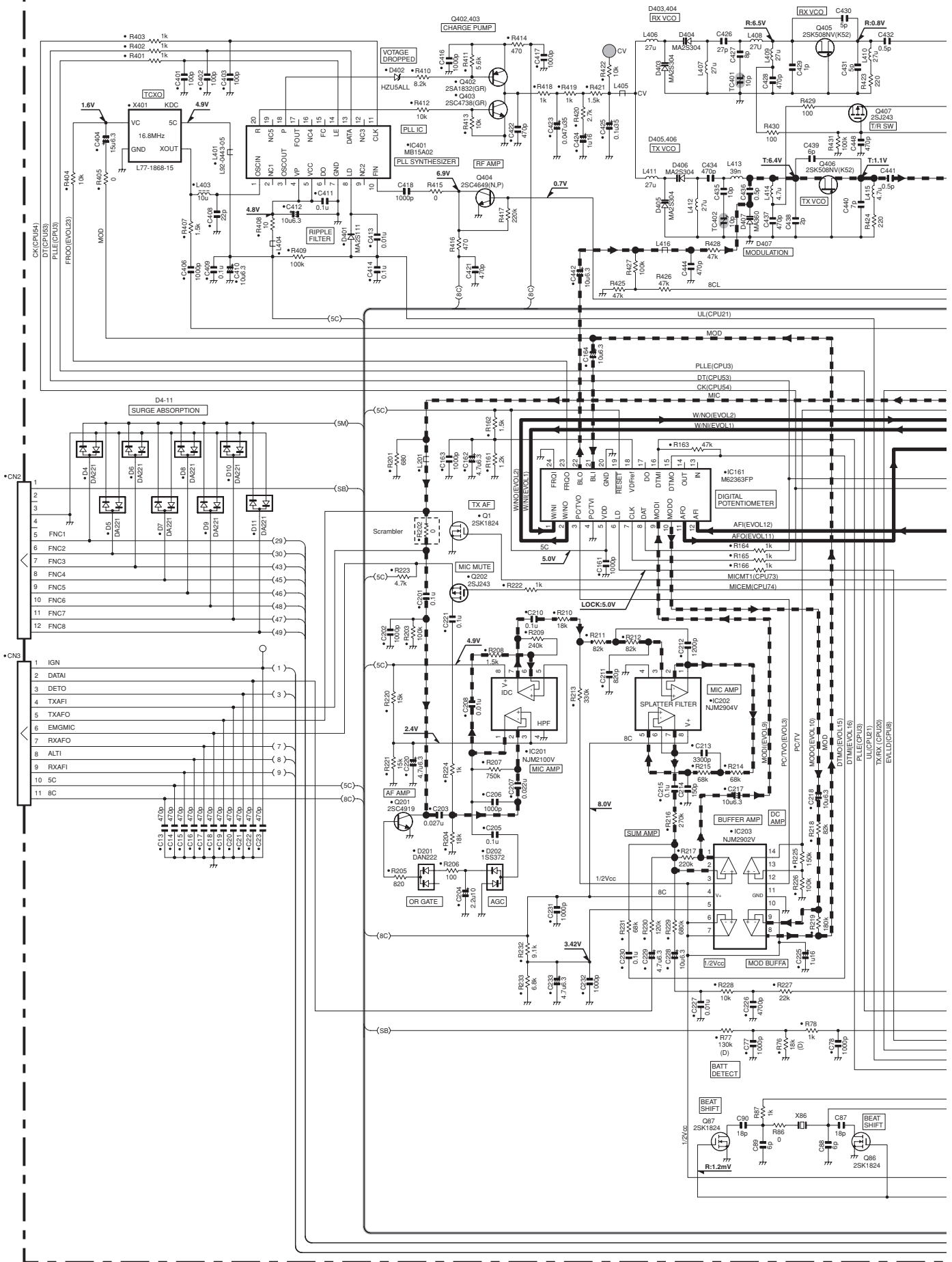

SCHEMATIC DIAGRAM / 原理图 TK-7108

TX-RX UNIT (X57-6913-01)

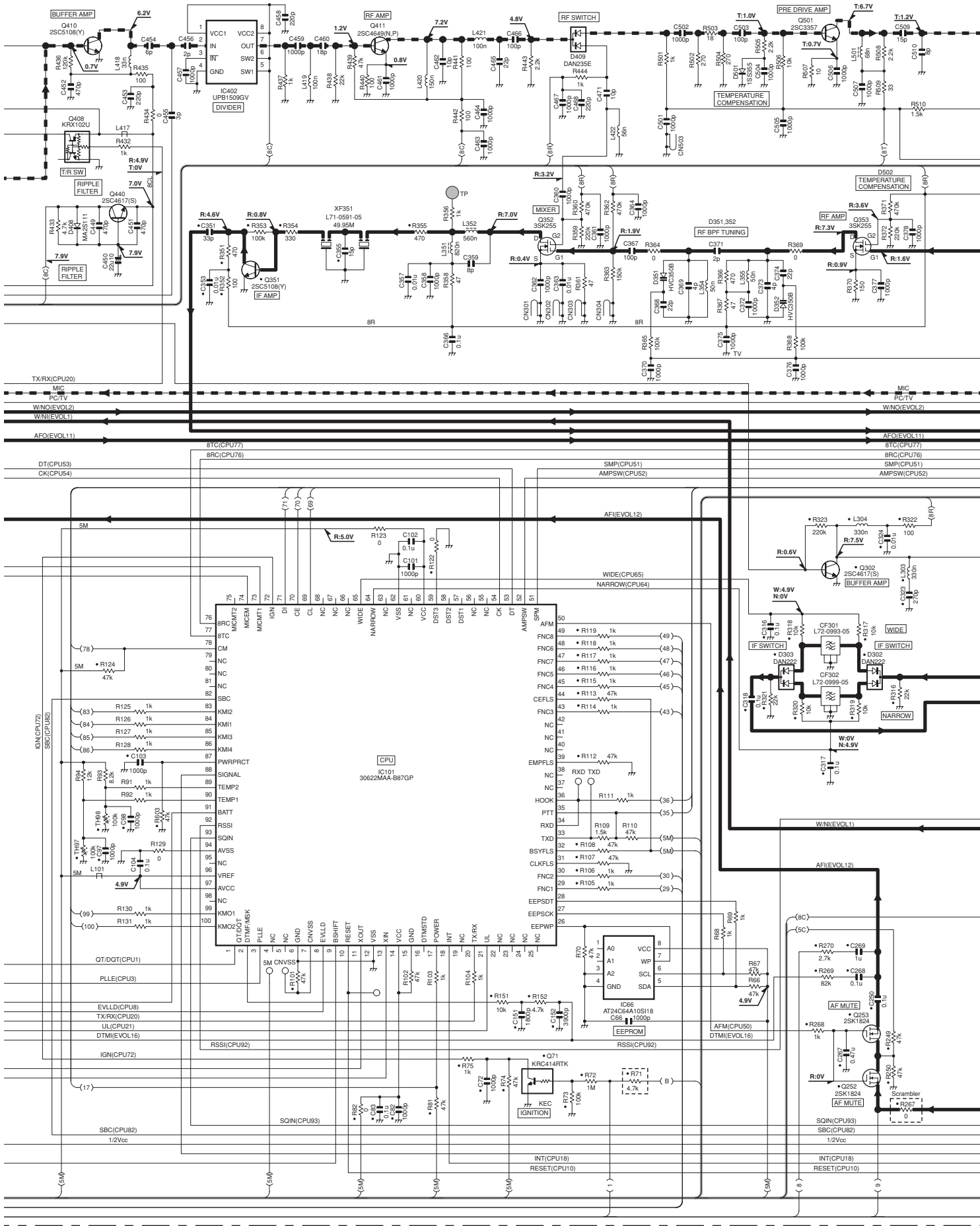

TK-7108 SCHEMATIC DIAGRAM / 原理图

TX-RX UNIT (X57-6913-01)

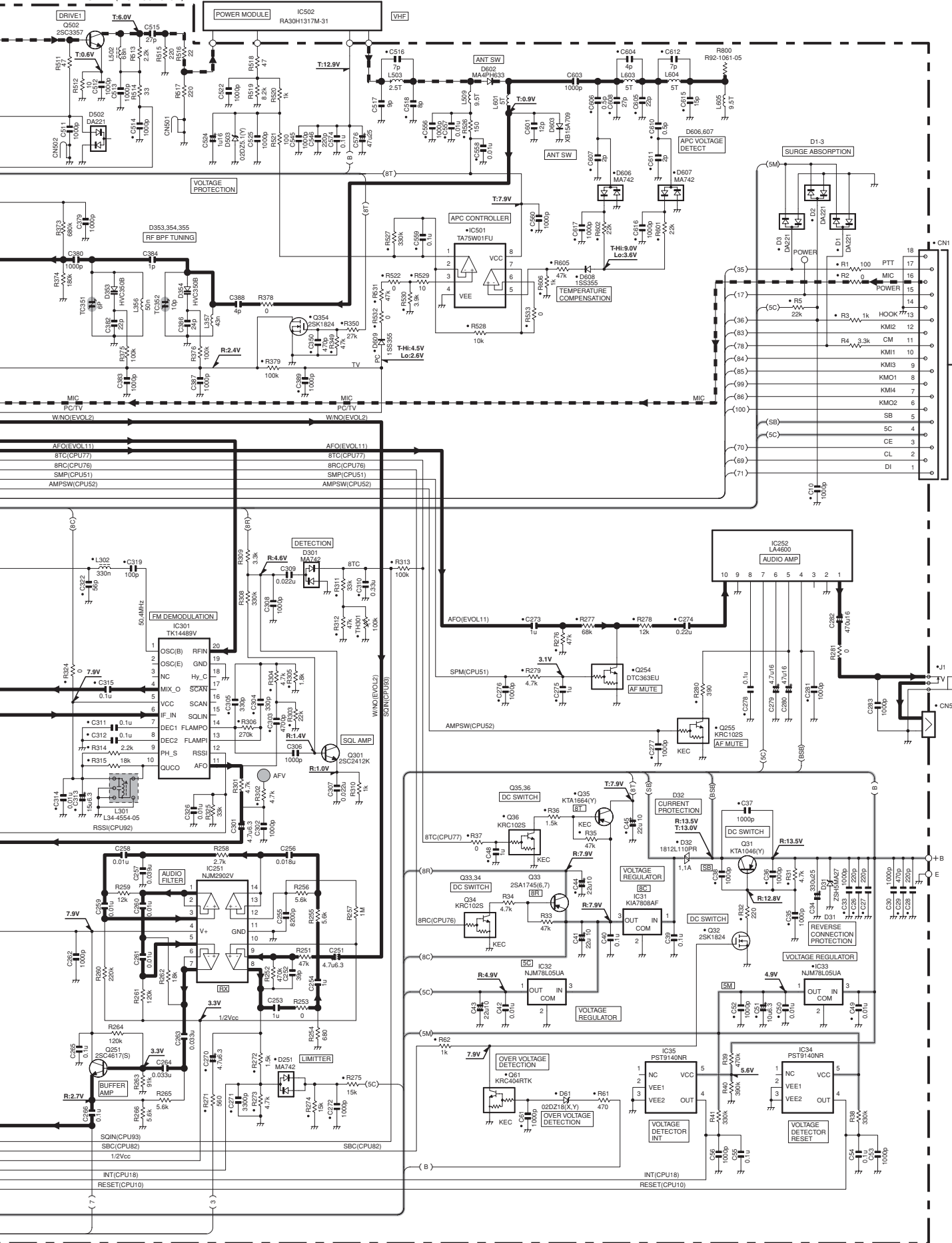

SCHEMATIC DIAGRAM / 原理图 TK-7108

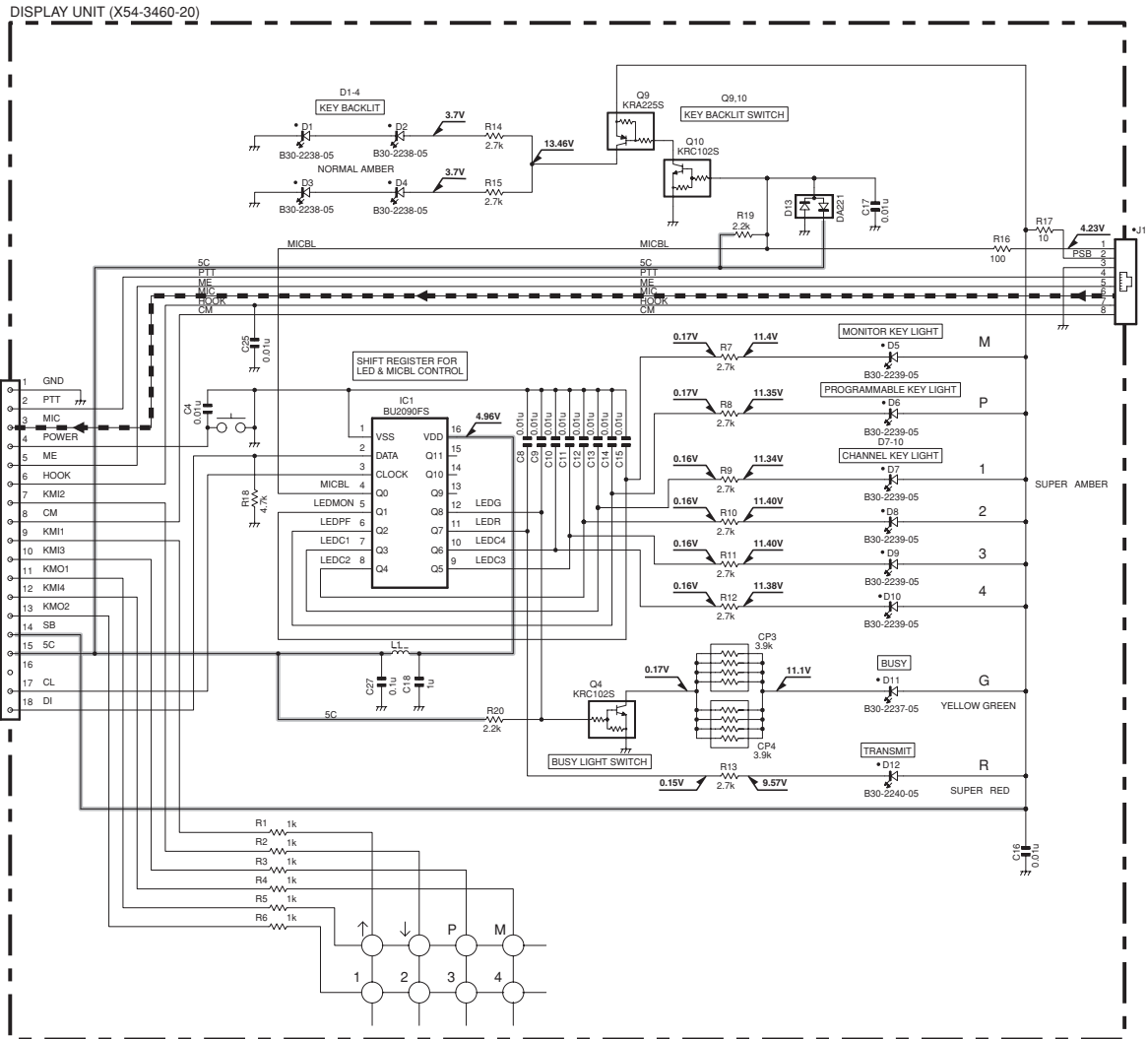

Note : The components marked with a dot (•) are parts of layer 1.

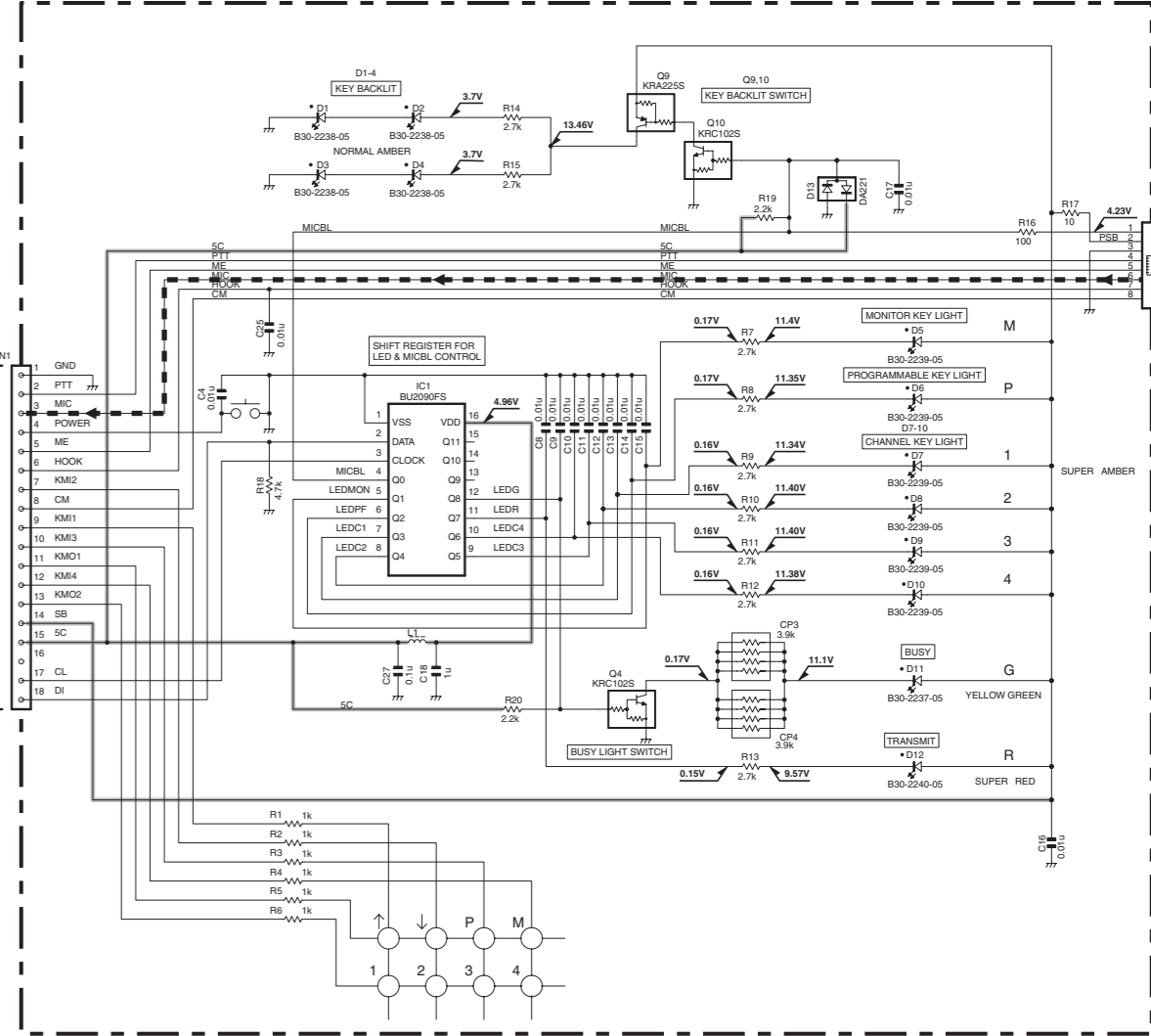
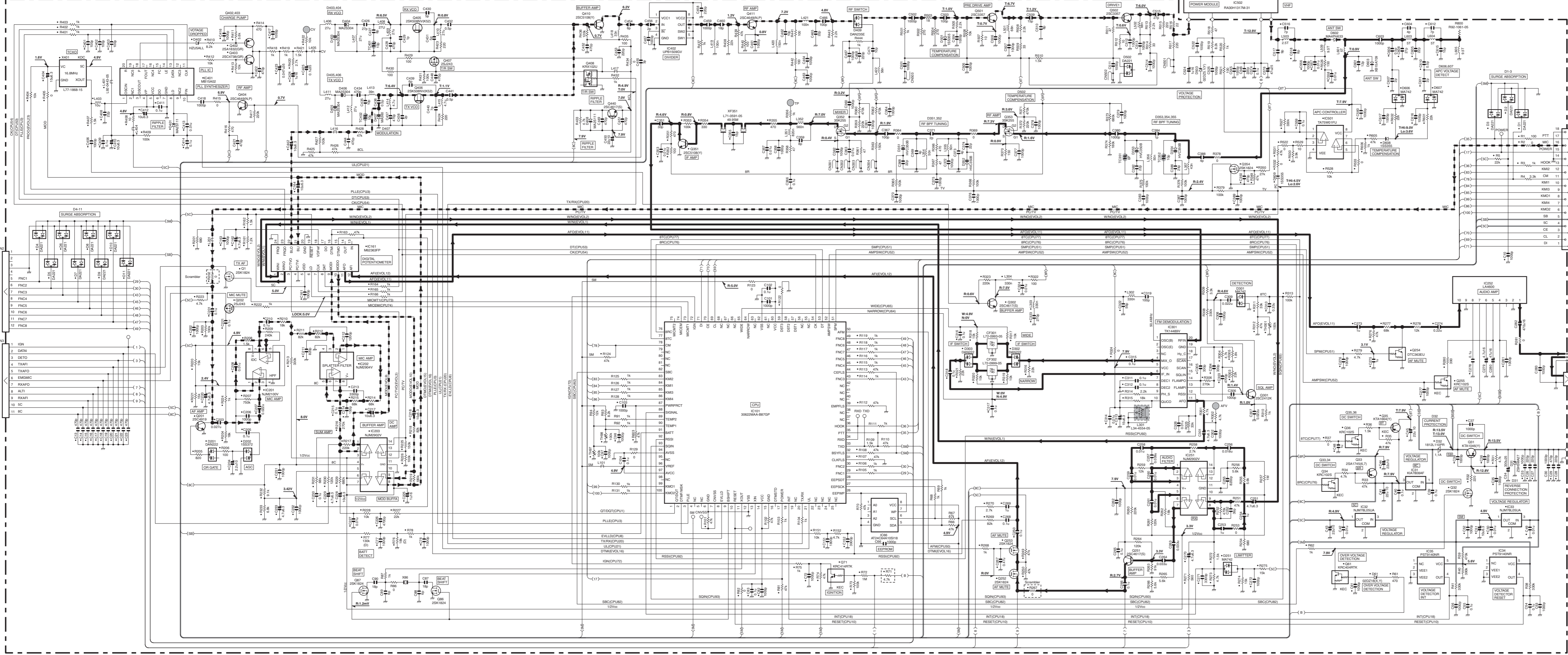

BLOCK DIAGRAM / 方块图

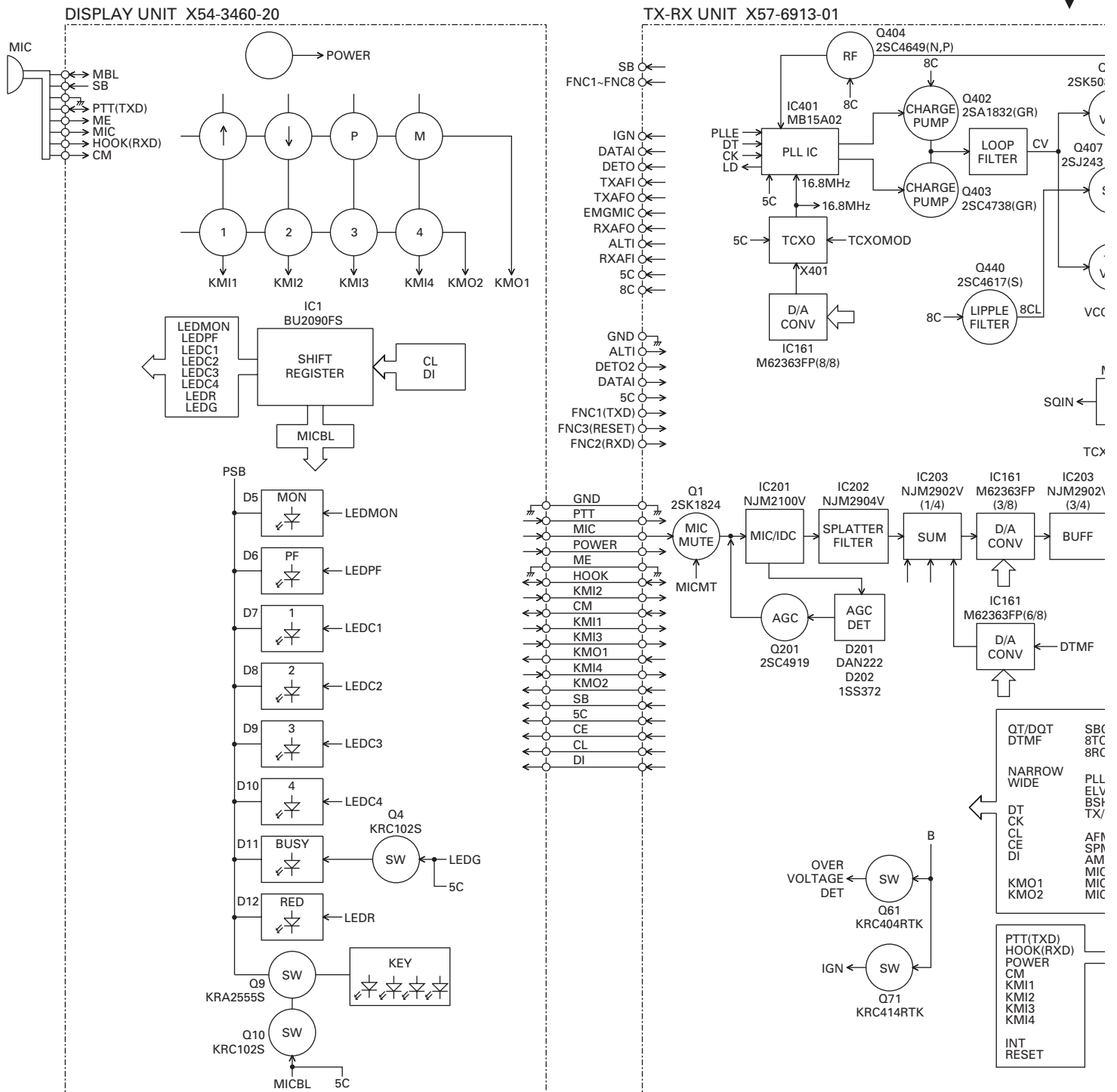

BLOCK DIAGRAM / 方块图

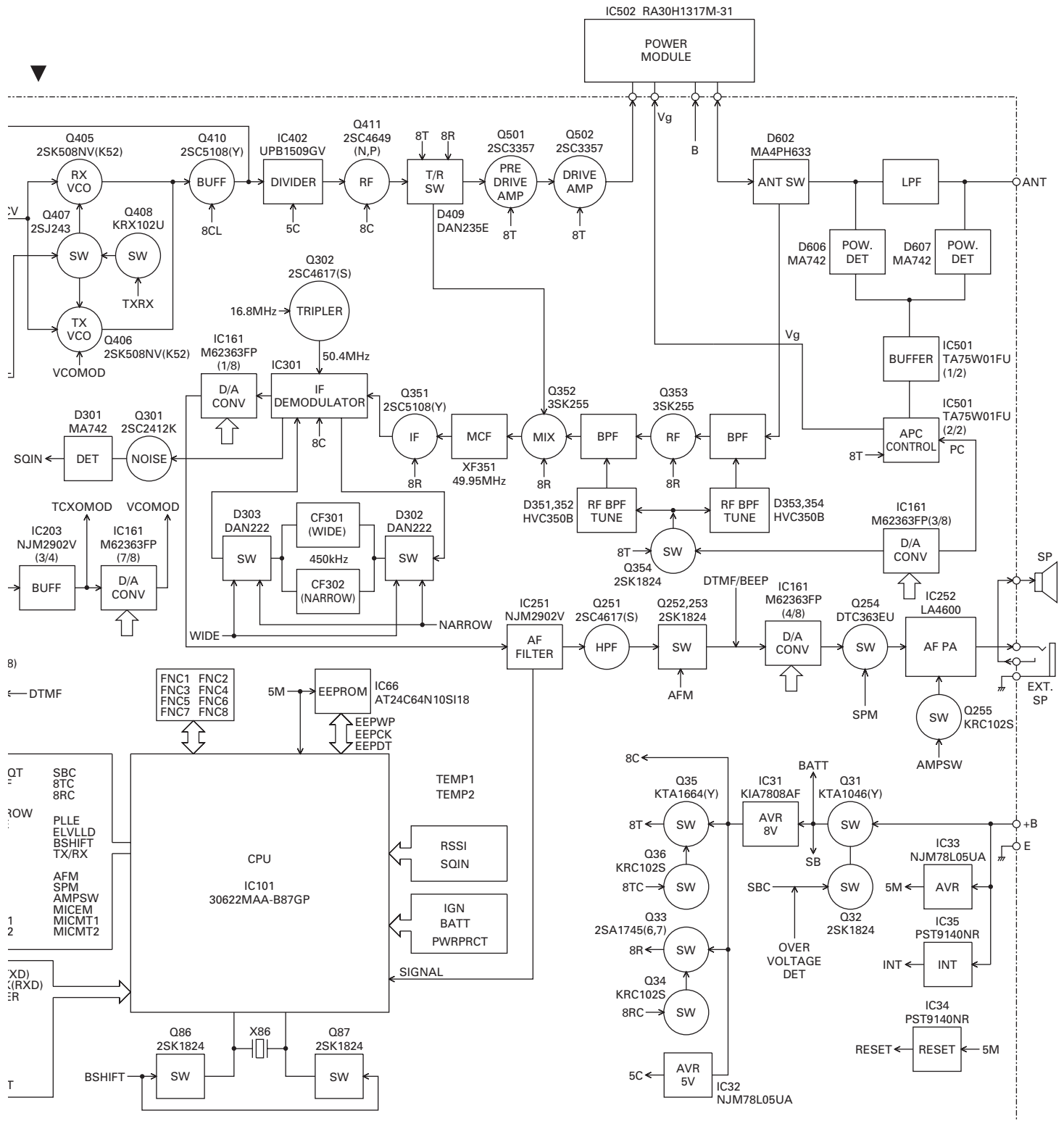

LEVEL DIAGRAM / 电平图

Receiver Section / 接收部

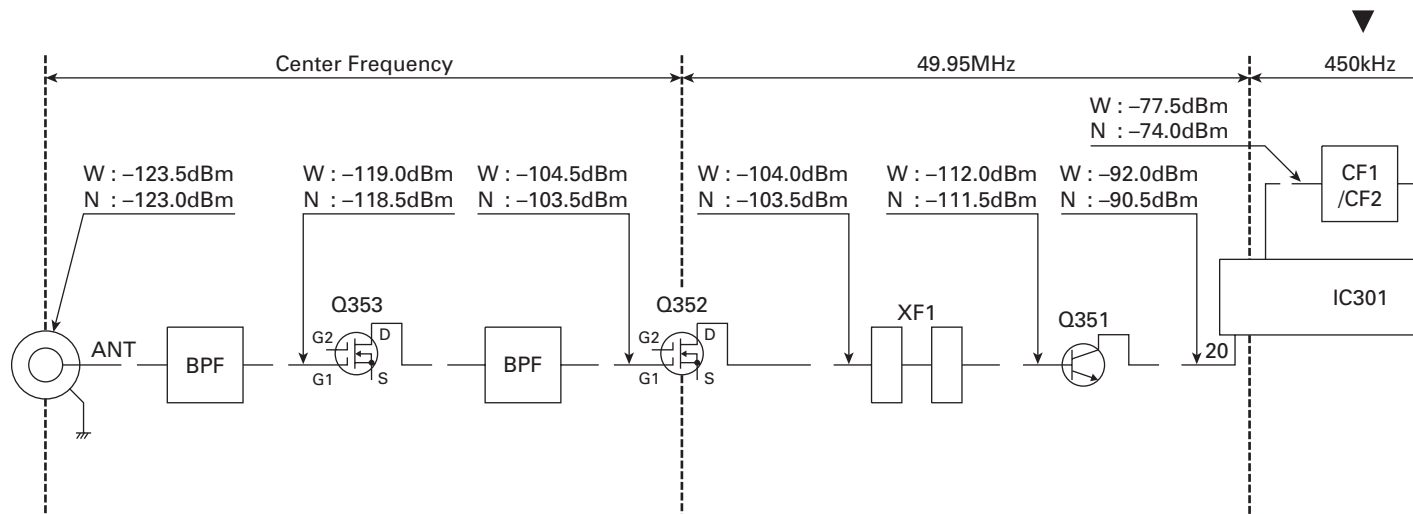

To make measurements in the RF section, connect the RF level meter.
 In the RF section, use a 0.01 μ F coupling capacitor.
 (The display shows the SSG input value required to obtain 12dB SINAD)

Transmitter Section / 发射部

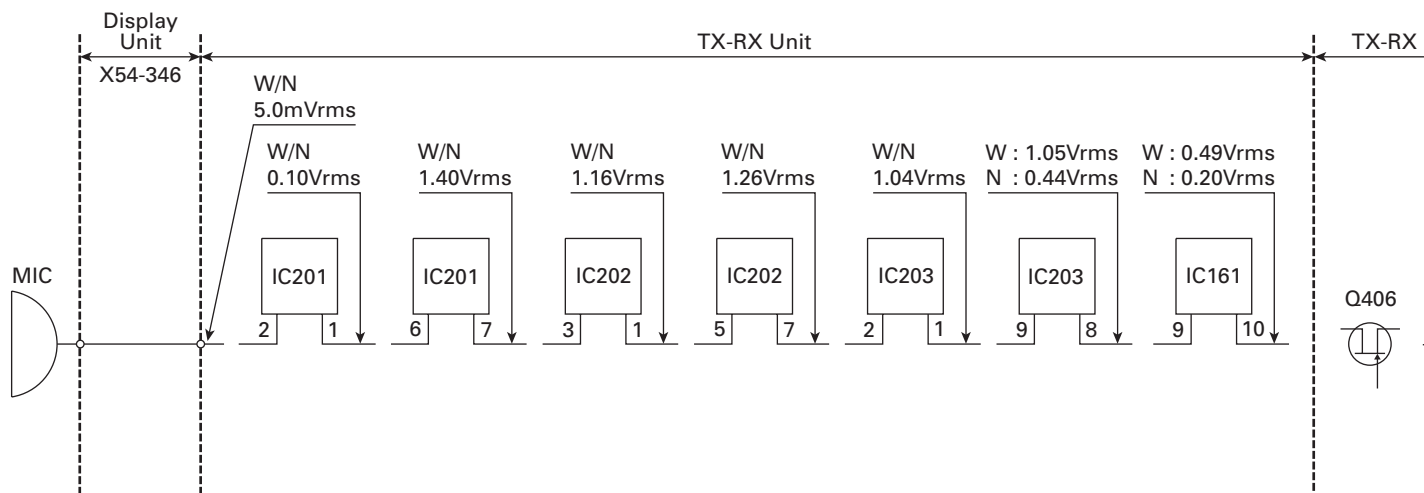

To make measurements in the AF section, connect the AC level meter.
 AG is set so that MIC input becomes 3kHz/1.5kHz (Wide/Narrow) DEV at 1kHz MOD.

To make

LEVEL DIAGRAM / 电平图

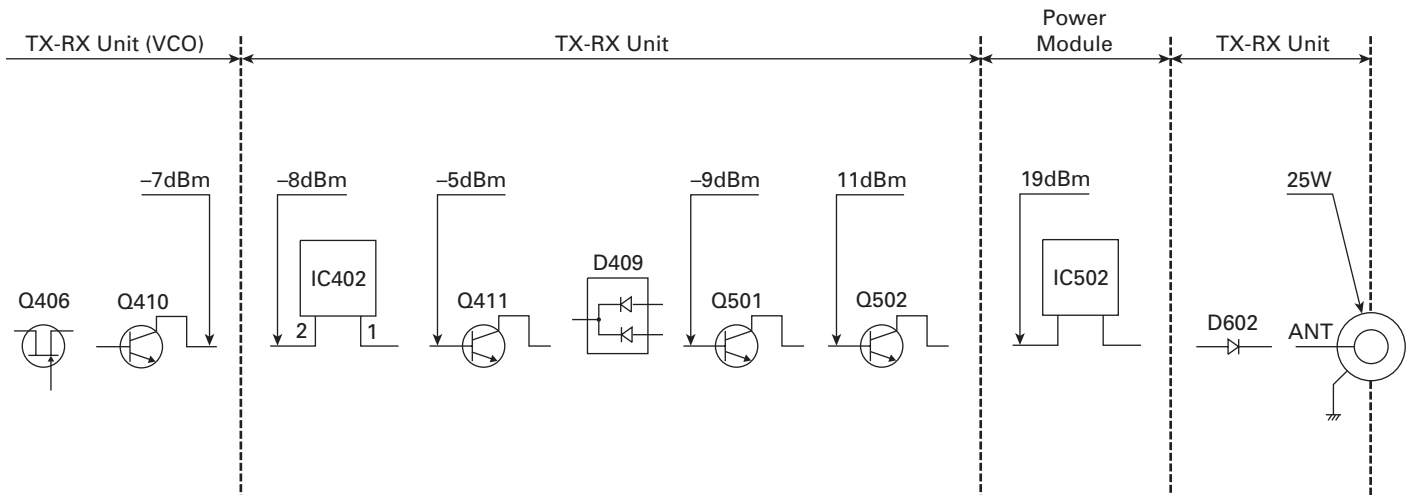
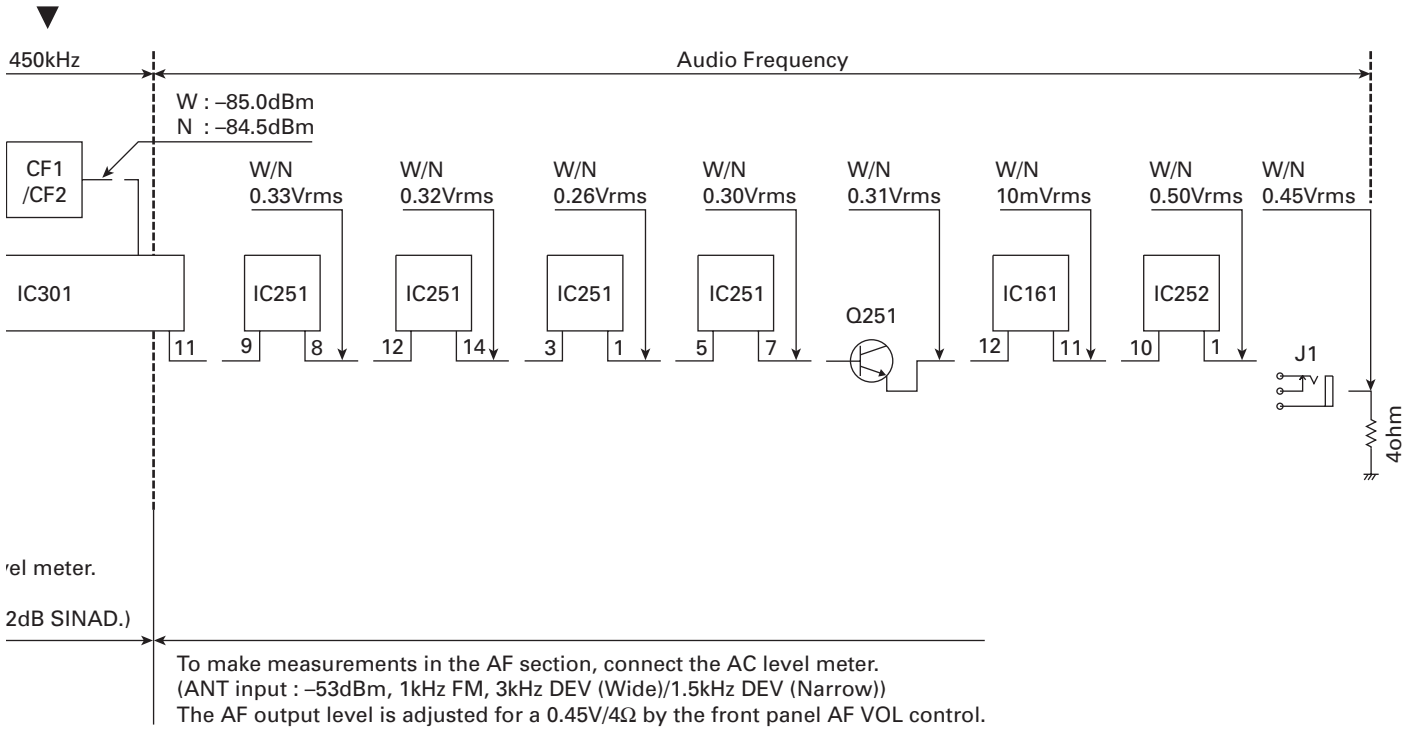

To make measurements in the RF section, connect the RF Wattmeter (50Ω).

▲

SPECIFICATIONS

GENERAL

Frequency Range	C,M : 146 to 174MHz
Number of Channels	8 channels
Channel Spacing	Wide : 25kHz Narrow : 12.5kHz
PLL Channel Stepping	2.5, 5, 6.25, 7.5kHz
Operating Voltage	13.6V DC \pm 15%
Current Drain	Less than 0.4A on standby Less than 1.0A on receive Less than 8.0A on transmit
Operating Temperature Range	-30°C to +60°C
Dimensions & Weight	160 W x 43 H x 107 D mm, 1.0kg
Channel Frequency Spread	28MHz

RECEIVER (Measurements made per EIA standard EIA/TIA-603)

Sensitivity (12dB SINAD)	Wide : 0.28 μ V Narrow : 0.35 μ V
Selectivity	Wide : 75dB Narrow : 65dB
Intermodulation	Wide : 70dB Narrow : 60dB
Spurious Response	75dB
Audio Power Output	4.0W
Frequency Stability	\pm 2.5ppm

TRANSMITTER (Measurements made per EIA standard EIA/TIA-603)

RF Power Output	High : 25W Low : 5W
Spurious and Harmonics	70dB
Modulation	Wide : 16K0F3E Narrow : 11K0F3E
FM Noise	Wide : 45dB Narrow : 40dB
Audio Distortion	Less than 3%
Frequency Stability	\pm 2.5ppm

规 格

概 述

频率范围	146 ~ 174MHz
信道数量	8信道
信道间距	宽：25kHz 窄：12.5kHz
锁相环电路步进频率	2.5, 5, 6.25, 7.5kHz
工作电压	13.6V直流 ± 15%
电流消耗	备用时：低于0.4A 接收时：低于1.0A 发射时：低于8.0A
工作温度范围	- 30℃到 + 60℃
尺寸和重量	160 (宽) × 43 (高) × 107 (长) 毫米, 约1.0kg
信道频率扩展	28MHz

接收部 (以每EIA标准EIA/TIA-603进行测量)

灵敏度 (12dB SINAD)	宽：0.28μV 窄：0.35μV
选 择 性	宽：75dB 窄：65dB
互 调	宽：70dB 窄：60dB
假信号响应	75dB
音频功率输出	4.0W
频率稳定性	± 2.5ppm

发射部 (以每EIA标准EIA/TIA-603进行测量)

射频功率输出	宽：25W 窄：5W
寄生谐波	70dB
调 制	宽：16K0F3E 窄：11K0F3E
频率调制噪音	宽：45dB 窄：40dB
音频失真	低于3%
频率稳定性	± 2.5ppm

KENWOOD CORPORATION

2967-3, Ishikawa-machi, Hachioji-shi, Tokyo, 192-8525 Japan

KENWOOD U.S.A. CORPORATION

P.O. BOX 22745, 2201 East Dominguez Street, Long Beach, CA 90801-5745, U.S.A.

KENWOOD ELECTRONICS CANADA INC.

6070 Kestrel Road, Mississauga, Ontario, Canada L5T 1S8

KENWOOD ELECTRONICS DEUTSCHLAND GMBH

Rembrücker Str. 15, 63150 Heusenstamm, Germany

KENWOOD ELECTRONICS BELGIUM N.V.

Leuvensesteenweg 248 J, 1800 Vilvoorde, Belgium

KENWOOD ELECTRONICS FRANCE S.A.

13, Boulevard Ney, 75018 Paris, France

KENWOOD ELECTRONICS U.K. LIMITED

KENWOOD House, Dwight Road, Watford, Herts., WD18 9EB United Kingdom

KENWOOD ELECTRONICS EUROPE B.V.

Amsterdamseweg 37, 1422 AC Uithoorn, The Netherlands

KENWOOD ELECTRONICS ITALIA S.p.A.

Via G. Sirtori, 7/9 20129 Milano, Italy

KENWOOD IBERICA S.A.

Bolivia, 239-08020 Barcelona, Spain

KENWOOD ELECTRONICS AUSTRALIA PTY. LTD.

(A.C.N. 001 499 074)

16 Giffnock Avenue, Centrecourt Estate, North Ryde, N.S.W. 2113 Australia

KENWOOD ELECTRONICS (HONG KONG) LTD.

Unit 3712-3724, Level 37, Tower one Metroplaza, 223 Hing Fong Road, Kwai Fong, N.T., Hong Kong

KENWOOD ELECTRONICS SINGAPORE PTE LTD.

1 Genting Lane #07-00 Kenwood Building, Singapore 349544

